

Grammar Minutes



Creative Teaching Press®

CTP 6123

ONE HUNDRED MINUTES TO BETTER BASIC SKILLS

- Builds basic skills
- Integrates a variety of skills
- Motivates and challenges students
- Promotes greater self-confidence
- Prepares students for success in testing situations
- Provides immediate feedback

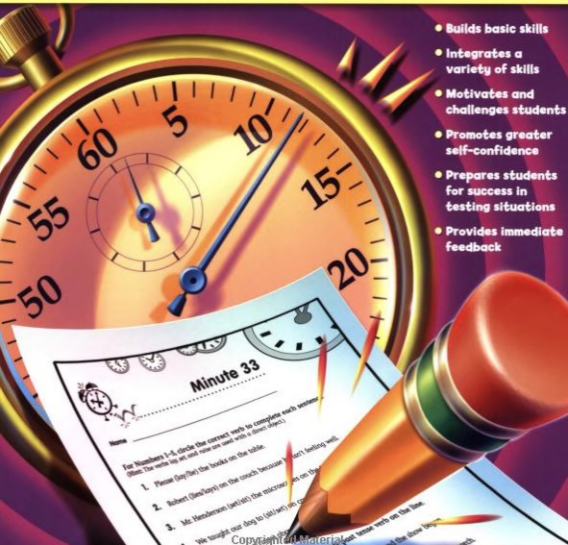

Minute 33

Name _____

For Numbers 1-3, circle the correct verb to complete each sentence.
(Hint: The verb you use will describe each with a direct object.)

1. Please (lay/be) the books on the table.
2. Robert (has/lays) on the couch because he isn't feeling well.
3. Mr. Henderson (set/sit) the microwave on the counter.

We taught our dog to (sit/set) on the floor.

Grammar Minutes

Written by
Kathleen Hex

Editors: Regina Hurh Kim/Gillian Snoddy
Cover Illustrator: Rick Grayson
Cover Designer: Rebekah O. Lewis
Production: Karen Nguyen
Art Director: Moonhee Pak
Project Director: Stacey Faulkner

© 2009 Creative Teaching Press Inc., Huntington Beach, CA 92649
Reproduction of activities in any manner for use in the classroom and not for commercial sale is permissible.
Reproduction of these materials for an entire school or for a school system is strictly prohibited.

Table of Contents



I ntr <u>o</u> duction	3
H ow to Use This Book	4
M inute Journal	6
S cope and Sequence	7
G rammar Minutes	8
A nswer Key	108



Introduction

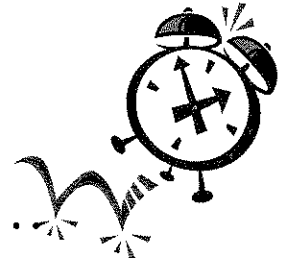

The main objective of *Grammar Minutes Grade 5* is grammar proficiency, attained by teaching students to apply grammar skills to answer questions effortlessly and rapidly. The questions in this book provide students with practice in the following key areas of fifth-grade grammar instruction:

- nouns
- verbs
- pronouns
- adjectives
- adverbs
- prepositional phrases
- types of sentences
- sentence structure
- appositives and clauses
- noun and pronoun agreement
- subject and verb agreement
- negatives
- prefixes and suffixes
- Greek and Latin roots

Use this comprehensive resource to improve your students' overall grammar proficiency, which will promote greater self-confidence in their grammar skills as well as provide the everyday practice necessary to succeed in testing situations.

Grammar Minutes Grade 5 features 100 "Minutes." Each Minute consists of 10 questions for students to complete within a short time period. As students are becoming familiar with the format of the Minutes, they may need more time to complete each one. Once they are comfortable and familiar with the format, give students a one- to two-minute period to complete each Minute. The quick, timed format, combined with instant feedback, makes this a challenging and motivational assignment that offers students an ongoing opportunity to improve their own proficiency in a manageable, nonthreatening way.



How to Use This Book



Grammar Minutes Grade 5 is designed to generally progress through the skills as they are introduced in the classroom in fifth grade. The Minutes can be implemented in either numerical order, starting with Minute 1, or in any order based on your students' specific needs during the school year. The complexity of the sentences and the tasks within each skill being covered gradually increase so that the first Minute of a skill is generally easier than the second Minute on the same skill. Review lessons are included throughout the book, as well as in an application section at the end of the book.

Grammar Minutes Grade 5 can be used in a variety of ways. Use one Minute a day as a warm-up activity, skill review, assessment, test prep, extra credit assignment, or homework assignment. Keep in mind that students will get the most benefit from each Minute if they receive immediate feedback.

If you use the Minute as a timed activity, begin by placing the paper facedown on the students' desks or displaying it as a transparency. Use a clock or kitchen timer to measure one minute—or more if needed. As the Minutes become more advanced, use your discretion on extending the time frame to several minutes if needed. Encourage students to concentrate on completing each question successfully and not to dwell on questions they cannot complete. At the end of the allotted time, have the students stop working. Read the answers from the answer key (pages 108–112) or display them on a transparency. Have students correct their own work and record their scores on the Minute Journal reproducible (page 6). Then have the class go over each question together to discuss the answers. Spend more time on questions that were clearly challenging for most of the class. Tell students that some skills that seemed difficult for them will appear again on future Minutes and that they will have another opportunity for success.



.....

Teach students the following strategies for improving their scores, especially if you time their work on each Minute:

- leave more challenging items for last
- come back to items they are unsure of after they have completed all other items
- make educated guesses when they encounter items with which they are unfamiliar
- ask questions if they are still unsure about anything

Students will ultimately learn to apply these strategies to other assignments and testing situations.

The Minutes are designed to assess and improve grammar proficiency and should not be included as part of a student's overall language arts grade. However, the Minutes provide an excellent opportunity to identify which skills the class as a whole needs to practice or review. Use this information to plan the content of future grammar lessons. For example, if many students in the class have difficulty with a Minute on commas, additional lessons in that area will be useful and valuable for the students' future success.

While Minute scores should not be included in students' formal grades, it is important to recognize student improvements by offering individual or class rewards and incentives for scores above a certain level on a daily and/or weekly basis. Showing students recognition for their efforts provides additional motivation to succeed.

Minute Journal

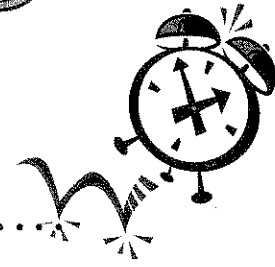

Name _____

Minute	Date	Score	Minute	Date	Score	Minute	Date	Score	Minute	Date	Score
1			26			51			76		
2			27			52			77		
3			28			53			78		
4			29			54			79		
5			30			55			80		
6			31			56			81		
7			32			57			82		
8			33			58			83		
9			34			59			84		
10			35			60			85		
11			36			61			86		
12			37			62			87		
13			38			63			88		
14			39			64			89		
15			40			65			90		
16			41			66			91		
17			42			67			92		
18			43			68			93		
19			44			69			94		
20			45			70			95		
21			46			71			96		
22			47			72			97		
23			48			73			98		
24			49			74			99		
25			50			75			100		

Scope and Sequence

MINUTE	SKILL
1.....	Complete Sentences
2.....	Simple Subjects and Predicates
3.....	Complete Subjects and Predicates
4.....	Compound Subjects and Predicates
5.....	Exclamatory and Interrogative Sentences
6.....	Imperatives and Declaratives
7.....	End Punctuation
8.....	Complete Sentences Review
9.....	Subjects and Predicates Review
10.....	More Subjects and Predicates Review
11.....	Types of Sentences Review
12.....	Common Nouns
13.....	Common and Proper Nouns
14.....	Capitalization: Proper Nouns
15.....	Plural Nouns
16.....	Regular and Irregular Plural Nouns
17.....	Singular Possessive Nouns
18.....	Plural Possessive Nouns
19.....	Subject and Object Pronouns
20.....	Reflexive and Possessive Pronouns
21.....	Relative and Indefinite Pronouns
22.....	Noun and Pronoun Agreement
23.....	Common and Proper Nouns Review
24.....	Plural Nouns Review
25.....	Possessive Nouns Review
26.....	Subject and Object Pronouns Review
27.....	Reflexive and Possessive Pronouns Review
28.....	Relative and Indefinite Pronouns Review
29.....	Action Verbs
30.....	Linking and Helping Verbs
31.....	Regular and Irregular Past Tense Verbs
32.....	More Present and Past Tense Verbs
33.....	Commonly Misused Verbs
34.....	Subject and Verb Agreement
35.....	More Subject and Verb Agreement
36.....	Action and Linking Verbs Review
37.....	Linking and Helping Verbs Review
38.....	Present and Past Tense Verbs Review
39.....	Commonly Misused Verbs Review
40.....	Subject and Verb Agreement Review
41.....	Adjectives

MINUTE	SKILL
42.....	More Adjectives
43.....	Comparative Adjectives
44.....	Comparative and Superlative Adjectives
45.....	Adverbs
46.....	More Adverbs
47.....	Comparative and Superlative Adverbs
48.....	Adjectives Review
49.....	Adverbs Review
50.....	Adjectives and Adverbs
51.....	More Adjectives and Adverbs
52.....	Prepositions
53.....	More Prepositions
54.....	Prepositional Phrases
55.....	More Prepositional Phrases
56.....	Articles
57.....	Conjunctions
58.....	Compound Sentences
59.....	Appositives and Clauses
60.....	Prepositions Review
61.....	Articles Review
62.....	Conjunctions Review
63.....	Compound Sentences Review
64.....	Appositives and Clauses Review
65.....	Compound Words
66.....	Synonyms
67.....	More Synonyms
68.....	Antonyms
69.....	More Antonyms
70.....	Homographs
71.....	Homophones
72.....	More Homophones
73.....	Synonyms and Antonyms Review
74.....	Homographs and Homophones Review
75.....	Negatives
76.....	Contractions
77.....	Commas
78.....	Negatives Review
79.....	Commas Review
80.....	Prefixes
81.....	Suffixes
82.....	Word Origins
83.....	Word Origins and Affixes Review
84-100.....	Apply Your Grammar Knowledge

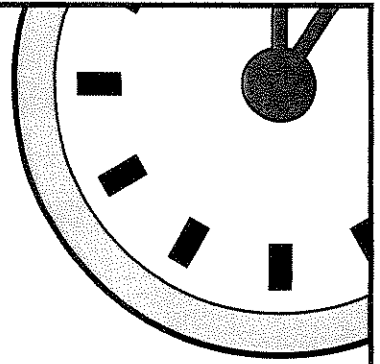
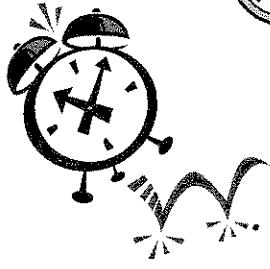

Minute 1

Name _____

Write *C* if the sentence is complete or *I* if it is incomplete.

1. Mom and Dad froze when they saw the mess in the garage. _____
2. Wonder why Jonas pulled the pickles from the shelf? _____
3. The first thing to do. _____
4. The oven was not hot enough to cook the casserole. _____
5. In all of the nicely decorated rooms. _____
6. At the end of the show, everyone cheered for Darla. _____
7. Imaginary lines that run east and west. _____
8. The dress rehearsal for the concert is Thursday night. _____
9. The rooster pecked furiously at the seeds. _____
10. A light in the lonely attic. _____



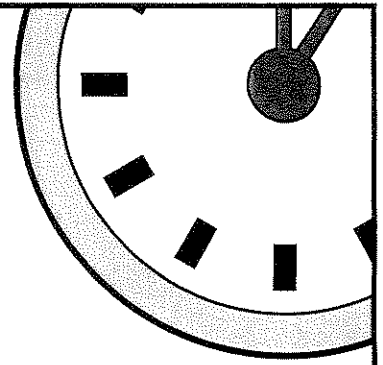
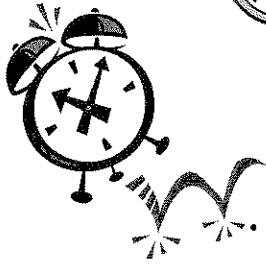

Minute 2

Name _____

For Numbers 1–5, underline the simple subject of each sentence.

(Hint: The *simple subject* is the someone or something the sentence is about. Example: The neighborhood dogs barked loudly.)

1. Ella walked to the store.
2. Giant squid grow 20 to 60 feet in length.
3. The night stars shine brightly.
4. The Petronas Towers in Kuala Lumpur rise over 1,400 feet.
5. In the office, the phones rang loudly.

For Numbers 6–10, circle the simple predicate of each sentence.

(Hint: The *simple predicate* is the action or linking verb without any other words that modify it or describe the subject. Example: The view overlooked the ocean.)

6. The famous artist Vincent Van Gogh painted *Sunflowers* in 1888.
7. *Shrek* is Hannah's favorite movie.
8. Trees sway gently in the breeze.
9. The Caldecott Medal is awarded each year to the best picture book.
10. A very sleepy Tyler came down the stairs to eat breakfast.

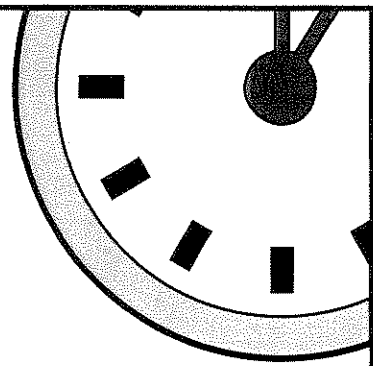
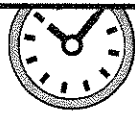

Minute 3

Name _____

For Numbers 1–5, underline the complete subject of each sentence.

(Hint: The *complete subject* includes all words related to whom or what the sentence is about.

Example: A crowded group of people stood in line for the bus.)

1. My sister Lindsey opened her umbrella.
2. The brand-new building was painted bright blue.
3. Alex's sister sliced the bread.
4. The elementary school students guessed how many buttons were in the jar.
5. The eager group of tourists watched the wild animals roam around the African savannah.

For Numbers 6–10, circle the complete predicate for each sentence below.

(Hint: The *complete predicate* includes all words that show what the complete subject is or does.

Example: A crowded group of people (stood in line for the bus.)

6. Kevin put his books in my backpack.
7. Downhill snow skiing is a fun winter sport.
8. The spring rains helped the flowers bloom.
9. After ringing up my purchase, the cashier politely handed me my receipt.
10. If the conductor is sick, Kate will take her place.

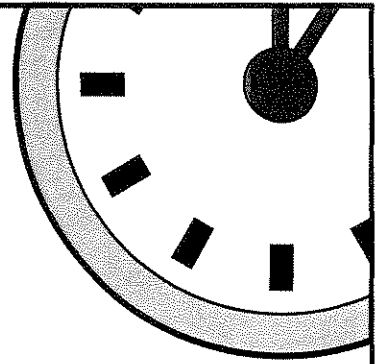
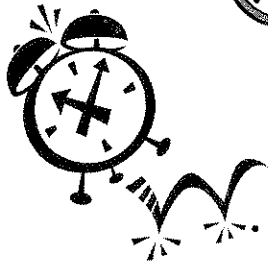

Minute 4

Name _____

For Numbers 1–5, underline the compound subject in each sentence.
(Hint: A *compound subject* has two or more simple subjects with the same predicate.
Example: A man and a child walked down the street.)

1. Gretchen and Thelma wandered through the park.
2. In the garden, roses and daisies were blooming all around us.
3. Sweaters, coats, and rugs are often made with wool.
4. The guard and the center worked together to keep the ball away from the opponents.
5. The United States, Canada, and Mexico are in North America.

For Numbers 6–10, write another verb to create a compound predicate for each sentence.

(Hint: A *compound predicate* has two or more predicates. Example: A man ate his sandwich and threw the wrapper away.)

6. Marianna washed the dishes and _____ the countertops.
7. The happy babies _____ and played in the bath.
8. Victor _____ music and played video games on his computer.
9. Owen feeds the horses, chickens, and pigs and _____ out the stables.
10. Every morning I eat breakfast, make my lunch, and _____ my school bag.

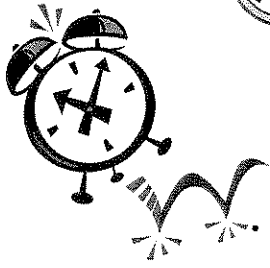

Minute 5

Name _____

For Numbers 1–4, circle the exclamatory sentence and underline the interrogative sentence.

(Hint: An *exclamatory* sentence shows strong feeling. An *interrogative* sentence asks a question.)

1. Look at that! Isn't that a gorgeous sunset?
2. I can't believe I missed the bus! What will I do now?
3. Was that your fastest swim record? It's unbelievable!
4. I can't believe it's broken! How long will it be before we can get it repaired?

For Numbers 5–7, insert correct end punctuation for each group of sentences.

5. Oh no ___ Sandra hurt her foot ___ Should she go to the doctor ___
6. Wow, look at the size of the trout ___ Is that the biggest fish you've ever caught ___
7. Are you ready ___ Hurry up or we'll be late ___ I think that's the bus ___

For Numbers 8–10, write an exclamatory sentence to fit with each sentence below.

8. _____ What happened to all the peanut butter?
9. _____ I can't concentrate.
10. _____ It is the best cupcake I've ever had!

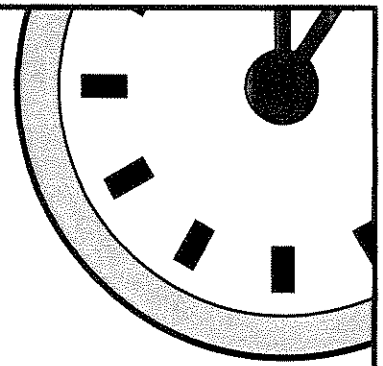
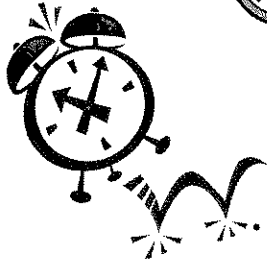

Minute 6

Name _____

Write *D* if the sentence is declarative. Write *I* if the sentence is imperative.
(Hint: A *declarative* sentence is a statement. An *imperative* sentence makes a request or a command. The "you" does not appear in the sentence but it is understood.)

1. Use the old stick to stir the paint. _____
2. We are learning the names of state capitals in school. _____
3. Draw a straight line from A to B. _____
4. Wear a sweater. _____
5. You are really friendly. _____
6. Lower the volume, please. _____
7. The dangerous substances were locked in Mrs. Tipper's science cupboard. _____
8. Use a pointer to indicate the correct coordinates on the map. _____
9. Board the bus before it leaves. _____
10. It is important that the doctor confirms the diagnosis. _____

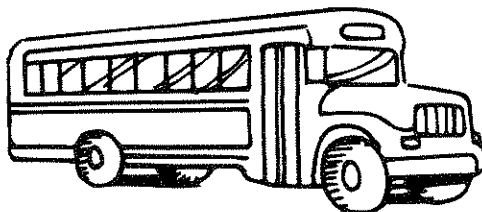

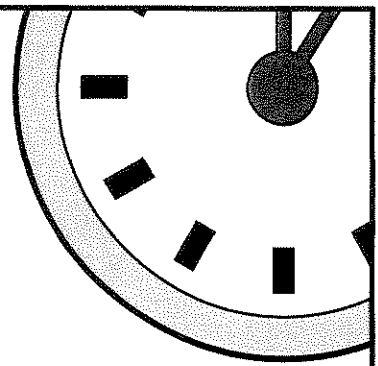
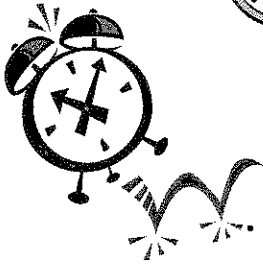

Minute 7

Name _____

Write the correct end punctuation (period, question mark, or exclamation point) for each sentence.

1. Satellites orbit around a planet ____
2. What's in the box ____
3. I enjoy the smell of ripening peaches ____

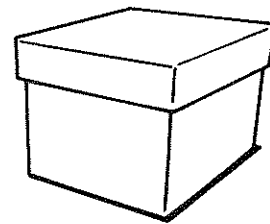

4. That is an amazing magic trick ____
5. Who is the boy wearing the purple shoes ____



6. Penguins cannot fly ____
7. You did a great job ____
8. Go get your jacket ____
9. Shannon will be the class president ____
10. What are you having for lunch ____

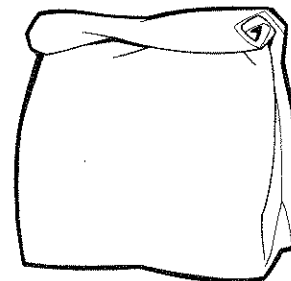

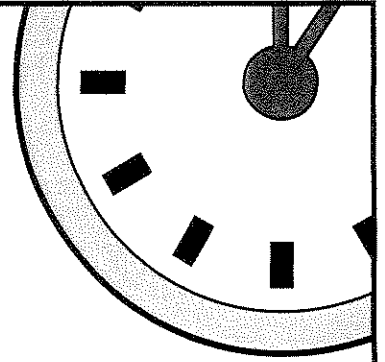
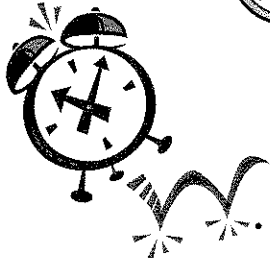

Minute 8

Name _____

Read each sentence. If it is a complete sentence, add the correct end punctuation mark. If it is an incomplete sentence, write *I* on the line.

1. Always wear a helmet when riding your bike or skateboard _____
2. Our teacher realized we were all beginning violin students _____
3. The meteorologist predicts the weather with great accuracy _____
4. The movie theater on N. Harbor Blvd _____
5. In the past, plantations grew cotton and tobacco _____
6. The money in my savings account for a new bicycle _____
7. Mr. Leonard Wallace Jr, the nicest neighbor on our street _____
8. When people enter the U.S., they are required to present a passport _____
9. All the time _____
10. In a seat aboard a private jet _____

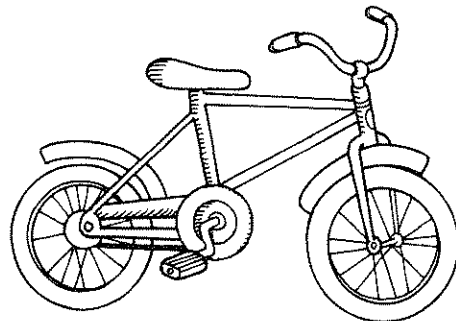
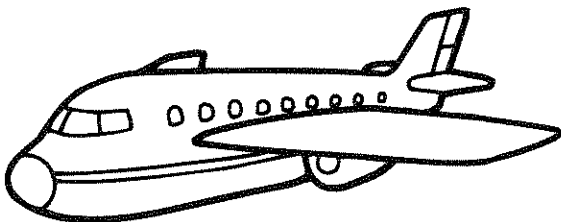

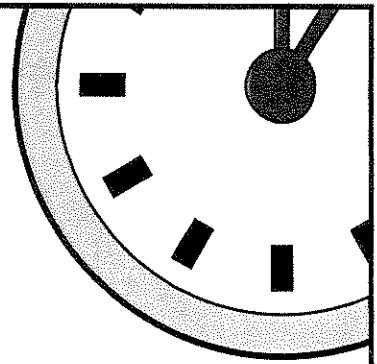
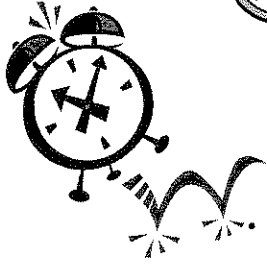

Minute 9

Name _____

Write *S* if the phrase is a subject or *P* if the phrase is a predicate.

- 1. many people _____
- 2. build their nests on the ground near a body of water _____
- 3. is the study of outer space _____
- 4. painted the ceiling of the Sistine Chapel in Rome _____
- 5. would be a great adventure _____
- 6. all of the renewable resources _____
- 7. as she walked home from school, Taylor _____
- 8. met at the park to practice for Saturday's game _____
- 9. Hillary and her family _____
- 10. escaped from chains and straightjackets as part of his act _____

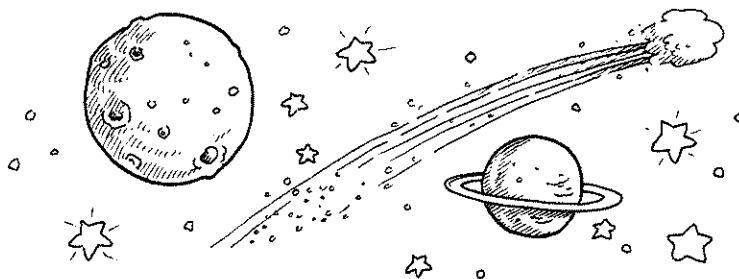

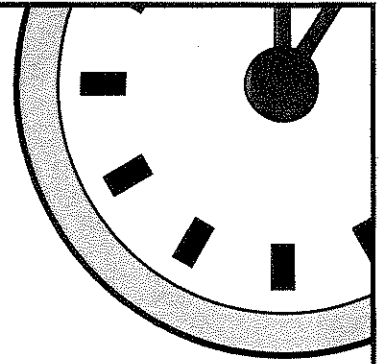

Minute 10

Name _____

For Numbers 1–5, circle the simple subject and underline the complete subject of each sentence.

1. A virus is a microscopic organism.
2. The Great Egyptian Pyramids were built as tombs.
3. My good friends Heather and Tony were the stars of the show.
4. The bright red robin sat on the branch of the tree.
5. The steaming hot chocolate warmed our chilly bones.

For Numbers 6–10, rewrite the sentence to include a compound predicate.

6. Martin walked to school.

7. All plants use oxygen and water.

8. My mother curled her hair.

9. Many Brazilians love to play soccer.

10. Rachel strolled along the boardwalk.

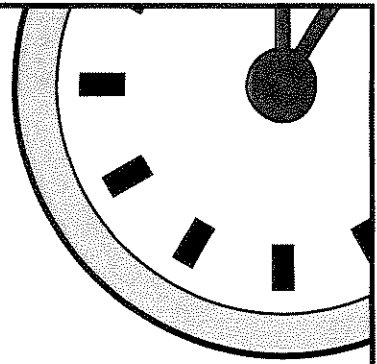

Minute 11

Name _____

Insert the correct punctuation at the end of each sentence. Then write the type of sentence it is on the line. Write *D* for declarative, *I* for interrogative, *IMP* for imperative, or *E* for exclamatory.

1. Matter is anything that takes up space ____
2. Dad, can you help me build a birdhouse ____
3. I won one million dollars ____
4. Think about it carefully ____
5. Did someone lose a jacket ____
6. Straighten your tie ____
7. Water boils at 212° Fahrenheit ____
8. How much money do we need ____
9. For the last time, Robert, clean up the mess ____
10. The green notebook is my math notebook ____

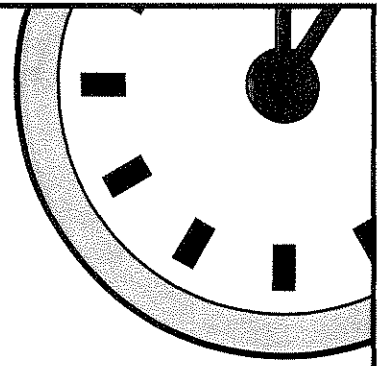

Minute 12

Name _____

Write each noun in the box under its correct category.

explorer	city	bucket	friendship
frequently	liberty	park	post office
galloped	shouted	biggest	woman
bread	veterinarian	purple	made

Person	Place	Thing or Idea
1. _____	4. _____	7. _____
2. _____	5. _____	8. _____
3. _____	6. _____	9. _____
		10. _____

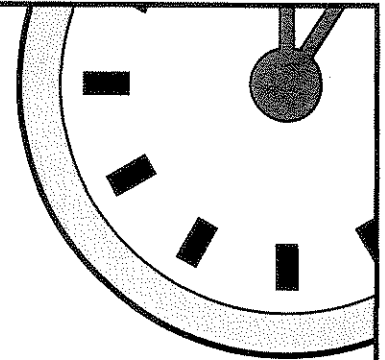
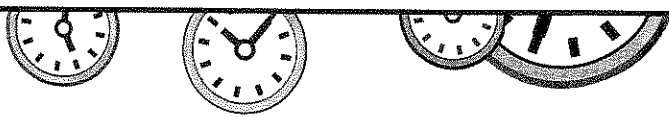

Minute 13

Name _____

Underline the common noun(s) and circle the proper noun(s) in each sentence.
(Hint: A *proper noun* names a specific person, place, thing, or idea.)

1. Jeff made a lot of friends at Onondaga Camp.
2. The glove felt just right to Javier.
3. The game took place in Central Park.
4. The students learned about the causes of the Revolutionary War.
5. Steven mixed all the ingredients together.
6. We met at Nick's house before going out to eat.
7. Our science teacher brought us to Hyde's Planetarium.
8. Byron Elementary School has a day off tomorrow.
9. The president of the United States lives in the White House.
10. They studied the pictures of Venus.

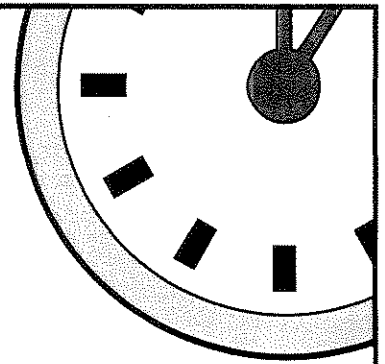

Minute 14

Name _____

Circle the proper noun that should be capitalized in each sentence.

1. The official languages in brazil are Portuguese, Spanish, English, and French.
2. Did you know that budapest is the capital of Hungary?
3. Millions of chinese people make a living by farming.
4. The Hindu Festival of Lights is called diwali.
5. The eiffel tower is located in Paris, France.
6. The most important book in Judaism is the torah.
7. There are more than 1 billion muslims in the world.
8. The smallest country in the world is vatican city.
9. My friend juanita, who is from Ecuador, is bilingual.
10. The walt disney concert hall in Los Angeles was opened in October 2003.

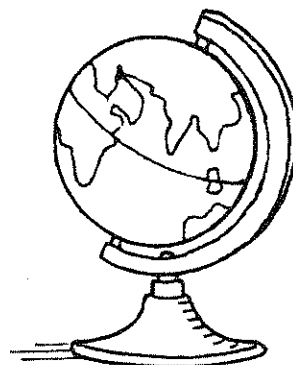
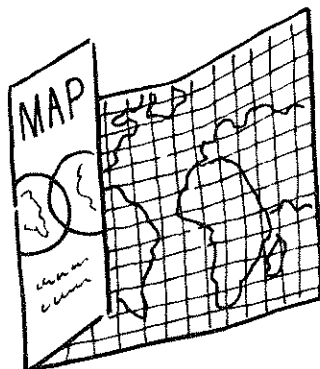

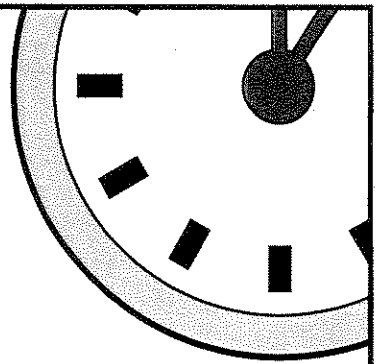
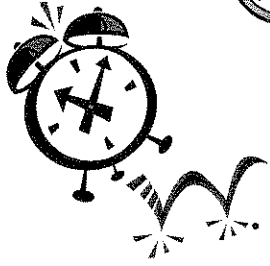

Minute 15

Name _____

Write the plural form for each noun.
(Hint: These plural nouns end in *-s*, *-es*, or *-ies*.)

1. shoe _____
2. hero _____
3. box _____
4. skate _____
5. monkey _____
6. company _____
7. princess _____
8. cherry _____
9. witch _____
10. chimney _____

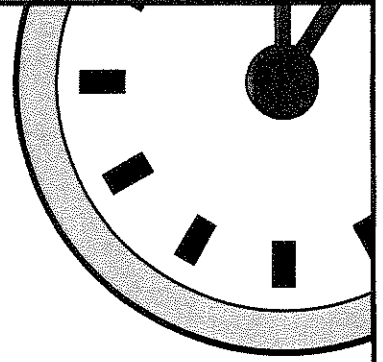

Minute 16

Name _____

Circle the two plural nouns in each sentence.

(Hint: There are some irregular plurals in these sentences that do not end in *-s*, *-es*, or *-ies*.)

1. The children visited many places on their field trip.
2. They took photos of two deer sipping water from the pond.
3. My grandmother's favorite dishes to make are scalloped potatoes and lemon cream pie.
4. On Thanksgiving Day, our family gets together with other families around our neighborhood to share our blessings and eat dinner.
5. The sheep grazed on the hills, undisturbed by the noise.
6. The paper and pens are on the top two shelves of the supply closet.
7. We raked the leaves into big piles.
8. My friends and I get together at the library to study for our weekly spelling and grammar quizzes.
9. Last December, when my mother and I opened the mall doors, we were greeted by elves.
10. Kevin likes horror movies, but I like biographies.

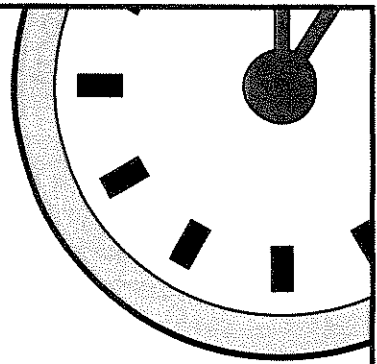
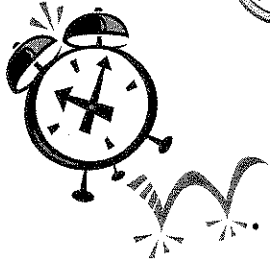

Minute 17

Name _____

Rewrite each phrase in possessive form.

(Hint: Adding 's to a singular noun makes it possessive. Example: The pencil belonging to Greg = Greg's pencil.)

1. The web of the spider _____
2. The cookie belonging to Teresa _____
3. The flute belonging to Kenneth _____
4. The lunch belonging to the student _____
5. The stethoscope belonging to the doctor _____
6. The father of the child _____
7. The shoes belonging to Ann _____
8. The legend of the map _____
9. The mascot of the team _____
10. The biography of the writer _____

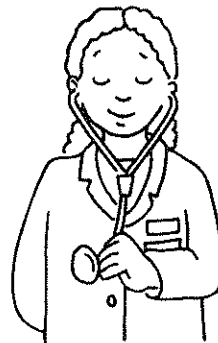
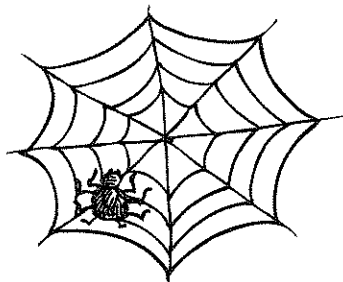

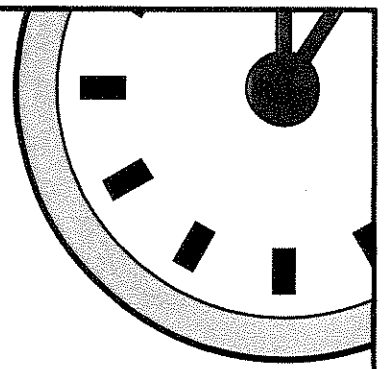
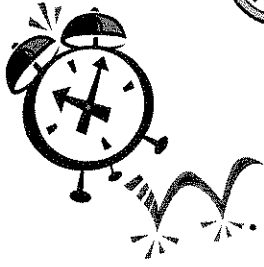

Minute 18

Name _____

Rewrite each phrase in possessive form.

(Hint: A *plural possessive noun* shows ownership by more than one person or thing. When a plural noun ends in -s, adding an apostrophe ['] to the end makes it possessive. Example: The room belonging to the sisters = sisters' room.)

1. The team of the boys _____
2. The lounge belonging to the teachers _____
3. The captains of the ships _____
4. The computers of the stores _____
5. The classroom of the children _____
6. The dresses belonging to the women _____
7. The projects of the partners _____
8. The colors of the leaves _____
9. The harnesses of the oxen _____
10. The hooves of the deer _____

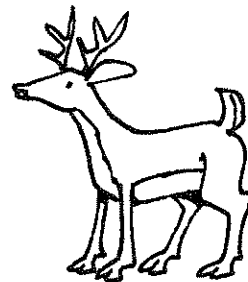
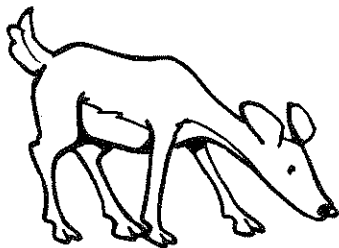

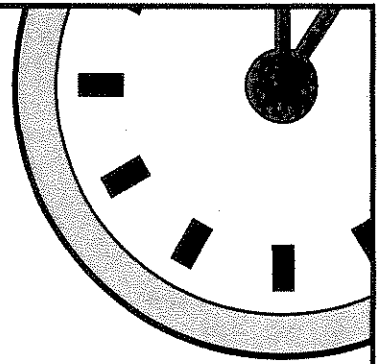

Minute 19

Name _____

For Numbers 1–5, write a subject pronoun to replace the underlined word or words in each sentence.

(Hint: A subject pronoun takes the place of one or more nouns in the subject of a sentence.

Example: Tae ate hungrily = *He* ate hungrily.)

1. Bill called Conner to ask about the homework assignment. _____
2. The girls changed quickly and went swimming. _____
3. Stella enjoys listening to music on her MP3 player. _____
4. The driver raced around the track at more than 200 miles per hour in his car. _____
5. Our guests stayed for two weeks. _____

For Numbers 6–10, circle the correct object pronoun(s) to complete each sentence.

6. Our principal challenged (we/us) to read 5,000 books this year.
7. Will Cathy go with (she/her) and (me/I) to the skate park?
8. The audience clapped loudly for (us/we).
9. The captains selected (she/her) and (me/I).
10. Mark wanted to buy baseball cards from (him/he) and (me/I).

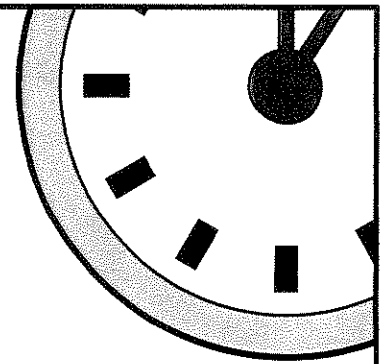
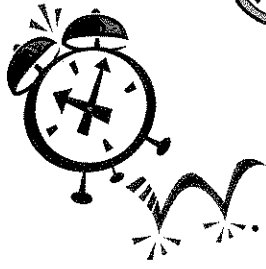

Minute 20

Name _____

For Numbers 1–5, write the correct reflexive pronoun to complete each sentence.

(Hint: A reflexive pronoun refers to the subject of the sentence. Use the words ending in *-self* if there is a single subject. Use the words ending in *-selves* for two or more subjects.)

1. I will help _____ to more cake.
myself yourselves
2. Each boy should mark _____ present on the attendance list.
themselves himself
3. "Lauren and David, make sure to pack some rain gear for _____."
yourself yourselves
4. The car sat by _____ in the parking lot.
itself themselves
5. The teacher said we can talk amongst _____.
ourselves ourself

For Numbers 6–10, underline the possessive pronoun(s) in each sentence.

(Hint: Possessive pronouns show ownership. Example: *Our* house is green.)

6. Devon asked Alice if he could borrow her pencil.
7. Ryan drove to my house quickly and parked his car.
8. Whose papers are on this table?
9. Lasagna is a favorite dish of mine.
10. Your birthday is two days before Lisa's birthday.

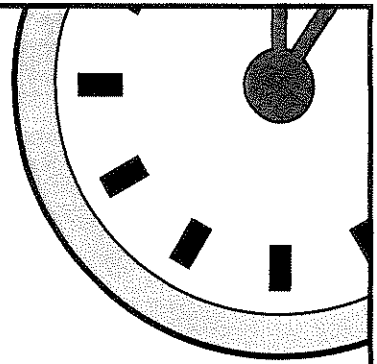

Minute 21

Name _____

For Numbers 1–5, use either of the relative pronouns *who* or *that* to correctly complete each sentence.

(Hint: Use *who* when referring to a person or *that* if referring to an object or animal.)

1. The customers _____ want a bargain will shop at Pick-n-Pay.
2. The lamp _____ my brother made is purple and yellow.
3. The student _____ has a hearing impairment won an award for bravery.
4. The monkey _____ ate his hat went to the veterinarian.
5. The person _____ is hungriest should eat first.

For Numbers 6–10, circle the indefinite pronoun in each sentence.

(Hint: An *indefinite* pronoun does not refer to a specific person, place, or thing.)

6. Anyone can go to the performance on Saturday.
7. There wasn't anything Jackson could have done to prevent the collision.
8. Antonio wants somebody to play tennis with on Thursday.
9. Can everyone see the board?
10. Each of the girls sent a birthday card to Jessica.

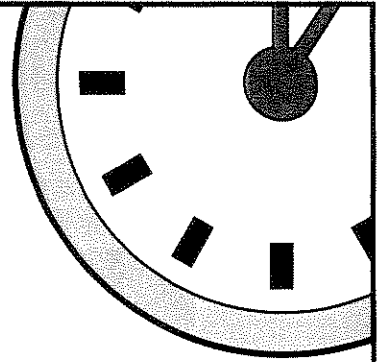

Minute 22

Name _____

Write the correct pronoun to complete each sentence.

1. Hybrid cars save gasoline, but _____ more expensive to buy.
it is they are
2. Lewis and Clark explored America with _____ corps of volunteers.
his their
3. Catherine the Great, empress of Russia, expanded _____ empire during her reign.
her their
4. Anybody who loses _____ ticket will not be admitted to the show.
their his
5. Both boys practiced _____ jump shot each night.
their his
6. Something under the bed moved _____ fluffy tail.
its their
7. People should brush _____ teeth twice a day.
their her
8. An electrician must complete extensive training before doing a job on _____ own.
their her
9. Campers should be especially careful when _____ near poison oak.
they are she is
10. The first time Wes and Tyson went bowling, _____ each scored over one hundred points.
they he

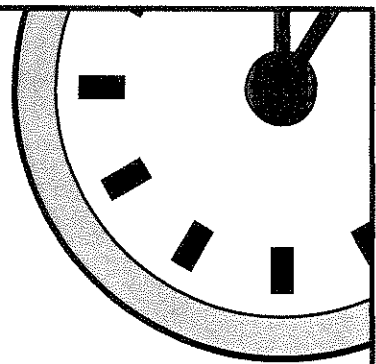

Minute 23

Name _____

Underline the common noun(s) and circle the proper noun(s) in each sentence.

1. When Charlene is hungry, she makes a sandwich.
2. The guitar was less expensive at Melody Music Shop.
3. Parker's birthday is January 27.
4. The Tour de France is a bicycle race through France.
5. Let's meet at the movie theater on Monday.
6. A squirrel raced through the trees in Highland Park.
7. My apartment is on the third floor.
8. Louise asked the banker for a loan.
9. The Statue of Liberty is in New York City.
10. Please take the garbage out.

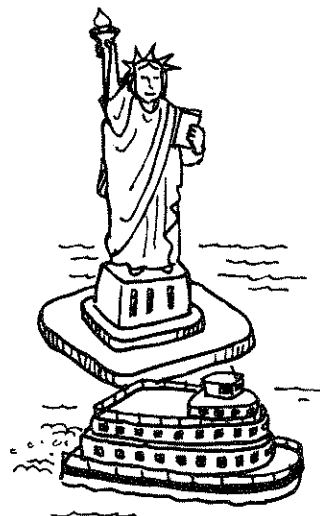

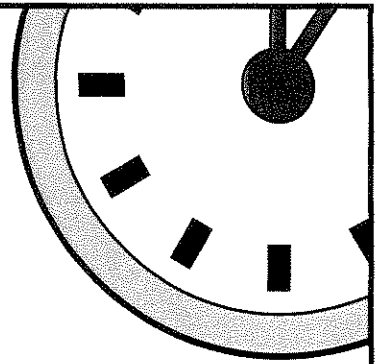
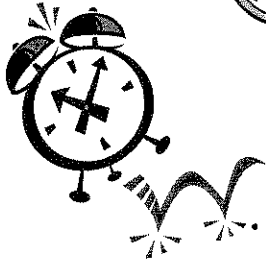

Minute 24

Name _____

For Numbers 1–5, read the paragraph and circle the five plural nouns. Write them on the lines.

The climbers set off to reach the summit of Mt. Kilimanjaro. They carried knives, cooking utensils, and food with them. It would take a long time to reach the top and set up camp. They had been training for months with people around the area. What victory it would be to finally reach their destination!

- 1. _____
- 2. _____
- 3. _____
- 4. _____
- 5. _____

For Numbers 6–10, write the plural form for each noun.

- 6. beetle _____
- 7. hobby _____
- 8. mouse _____
- 9. half _____
- 10. echo _____

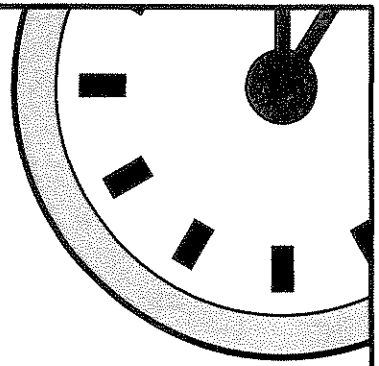

Minute 25

Name _____

For Numbers 1–5, rewrite each phrase in possessive form.

1. The department for men

2. The bookshelf belonging to Cindy

3. The windows of the galleries

4. The crayons belonging to the kindergartner

5. The water bottles belonging to the runners

For Numbers 6–10, underline the singular possessive phrase and circle the plural possessive phrase in each sentence.

6. Melissa's motorcycle ran more smoothly than her friends' motorcycles.

7. The Dolphins' victory made Dad's day.

8. The flowers' pollen affected Jessica's allergies.

9. I don't like to walk to Daria's Grocery Store because of the neighborhood dogs' loud barking as I enter their territory.

10. Lisa's pet hamster can't climb onto the sofas' slippery cushions.

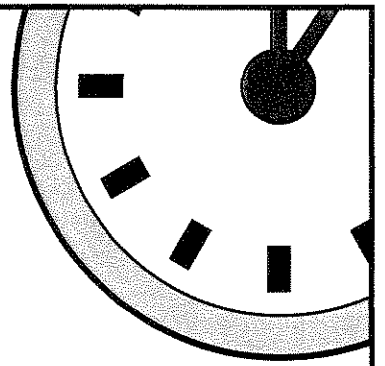
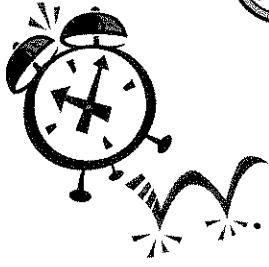

Minute 26

Name _____

For Numbers 1–5, circle the correct object pronoun(s) to complete each sentence.

1. Mom made lasagna for my brother and (me/I).
2. Mrs. Green chose Warren and (she/her) to finish the math problems on the board.
3. The puppy followed (they/them) home from the park.
4. The calculators belong to (she/her) and (he/him).
5. Lisa asked (he/him) and (I/me) to go to the movies.

For Numbers 6–10, write a subject pronoun to replace the underlined word or words in each sentence.

6. Ronald appears in many television commercials. _____
7. The turtle sunned itself on the rocks. _____
8. Air pollution is hazardous to the earth and to humans' health. _____
9. The twins will receive an award for their volunteer work at the daycare center. _____
10. Erin and I earn money by mowing our neighbors' lawns. _____

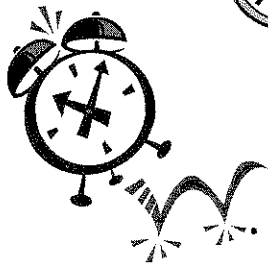

Minute 27

Name _____

For Numbers 1–5, write the correct possessive pronoun to complete each sentence.

1. When Jenna's baby brother laughs, _____ new baby teeth show.
2. _____ neighbor's house has lights that turn off automatically.
3. Trent and Carla are working on _____ project.
4. Even though Liz said she wasn't good at bowling, I found out _____ top score in bowling is 219.
5. We could hardly believe _____ eyes.

For Numbers 6–10, write the correct reflexive pronoun from the box to complete each sentence.

themselves herself himself itself yourself

6. Henry built a clubhouse all by _____.
7. Kenlyn ate a hot dog, but Sarah made a salad for _____.
8. He and his friends bought concert tickets for _____.
9. You should drive to the store by _____.
10. A lizard can grow _____ a new tail.

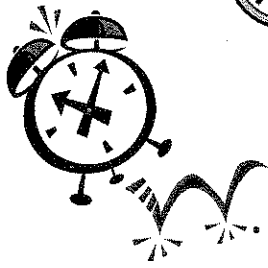

Minute 28

Name _____

For Numbers 1–5, circle the correct relative pronoun to complete each sentence.

1. Mother Teresa was a woman (who/that) served the poor her entire life.
2. The antique chair (who/that) belongs to my mother is a family heirloom.
3. Belinda has a favorite hat (who/that) once belonged to her sister.
4. The television (who/that) has loud speakers is better for playing video games.
5. The person in the drama club (who/that) raises the most money for the trip will win a prize.

For Numbers 6–10, write *Yes* if the indefinite pronoun in the phrase is used correctly. Write *No* if it is not.

6. Many of the students put his backpacks under the desks. _____
7. Either boy can drive his truck. _____
8. Someone brought their skateboard into the house. _____
9. Does everyone have their homework finished? _____
10. Both of the boys received telescopes for their birthdays. _____

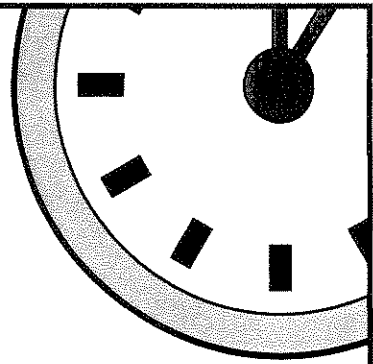

Minute 29

Name _____

Underline the action verb in each sentence. Write another action verb on the line to replace the one you underlined.

1. The glider soars through the air. _____
2. Evan drives over the Rocky Mountains. _____
3. The stars sparkle in the night sky. _____
4. The lamb leaps across the meadow. _____
5. Marcy and Mike skate to the park. _____
6. The farmer cuts the corn. _____
7. The storm is here, and I lost my umbrella. _____
8. The boat sails into the harbor. _____
9. The diver is not afraid as he swims. _____
10. Helen is happy because she hit a home run. _____

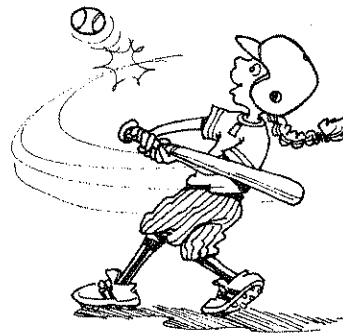
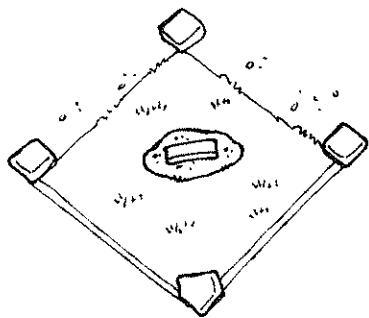

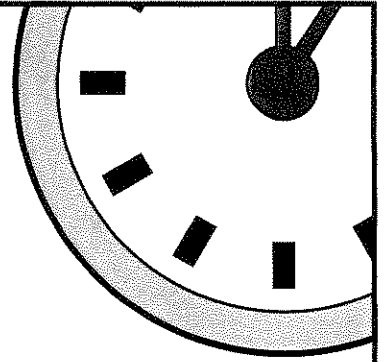
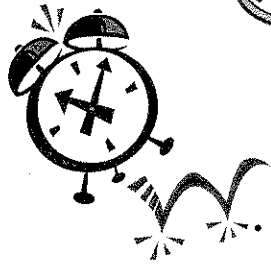

Minute 30

Name _____

For Numbers 1–5, underline the linking verb in each sentence.

(Hint: A *linking verb* does not express action. It connects the subject to the rest of the information about the subject.)

1. That octopus is large and scary.
2. I am sleepy after my long trip.
3. Apples are my favorite fruit.
4. The animals in the zoo are interesting to watch.
5. The airplanes were all late because of the storm.

For Numbers 6–10, circle the sentence in each pair that has a helping verb.

(Hint: A *helping verb* is the first word of a verb phrase and often sets the time and mood.)

6. a. She will go to the movies with Brenda.
b. She watched the movie with Brenda.
7. a. Janice and Nicolas helped their mother with the cooking.
b. Janice and Nicolas are helping their mother cook.
8. a. We meet to play soccer on Wednesday.
b. We have been playing soccer for an hour.
9. a. She is nice.
b. She is acting nice.
10. a. I am going to my house.
b. I want to go home.

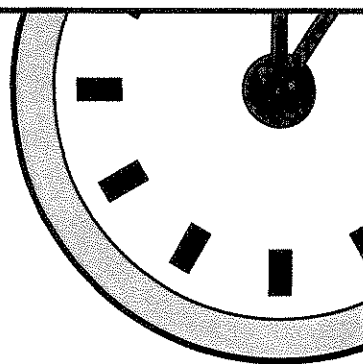

Minute 31

Name _____

Write the past tense forms of each verb below.
(Hint: Not all past tense verbs end in *-ed*.)

Present Tense

Past Tense

1. sail

2. scream

3. fly

4. answer

5. grow

6. act

7. wear

8. write

9. boil

10. break

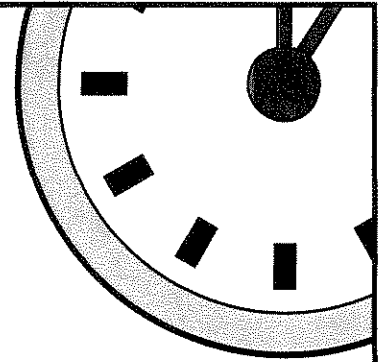

Minute 32

Name _____

Add *-ed* or *-ing* to the verb to correctly complete each sentence.

1. Who _____ the Internet?
invent
2. The lionesses _____ in the cool hours of the evening.
hunt
3. Travis was _____ about his bicycle tricks.
joke
4. Mrs. Jones _____ there would be a math test on Thursday.
mention
5. Thousands of people are _____ to warmer locations.
move
6. The sporting goods store is _____ a discount for frequent shoppers.
offer
7. The queen _____ the country for more than 40 years.
rule
8. Shelly is _____ a surprise birthday party for her mother.
plan
9. The workers are _____ the produce for the restaurant.
unload
10. Aunt Betsy is _____ from Vermont for a week.
visit

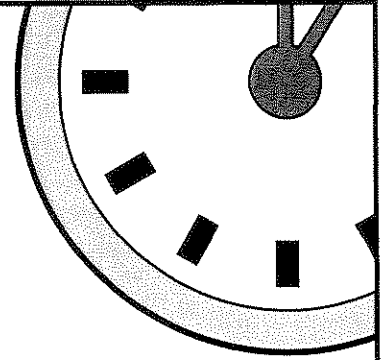
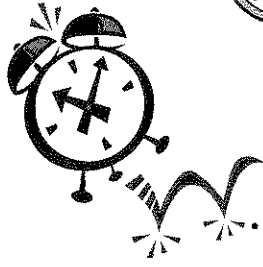

Minute 34

Name _____

For Numbers 1–5, write the correct form of the verb to complete each phrase.

Example: Wait

I wait

You wait

He waits

They wait

1. Laugh

I _____

You _____

She _____

They _____

2. Ask

I _____

You _____

He _____

They _____

3. Start

I _____

You _____

It _____

They _____

4. Paint

I _____

You _____

He _____

They _____

5. Dance

I _____

You _____

She _____

They _____

For Numbers 6–10, circle the correct verb form to complete each sentence.

6. Jerry and June (mops/mop) the floor.

7. The fifth-grade class (plant/plants) a tree every year.

8. The bee (stings/sting) the predator who threatens it.

9. He (turn/turns) off the light when leaving the room.

10. Fran (ignore/ignores) the telephone while she is studying.

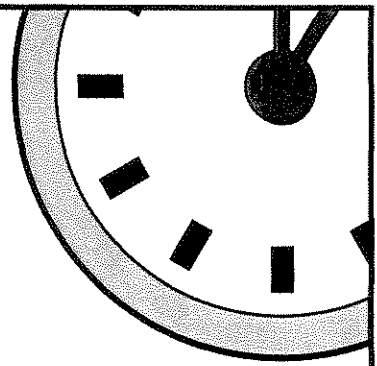

Minute 35

Name _____

Circle the correct verb form to complete each sentence.

1. Our baseball team (is/are) the best in the state.
2. The class (earn/earns) a quarter for each bake sale item sold.
3. The number of people who like Brussels sprouts (is/are) very small.
4. The hills (is/are) gleaming with white snow.
5. Doctors (is/are) very caring people.
6. Chandra's glasses (is/are) on her desk.
7. Raven and Jan (is/are) playing tetherball.
8. Either William's brother or my mom (drive/drives) us to school.
9. Neither Chris nor James will (wear/wears) braces anymore.
10. The scissors (is/are) in the top drawer.

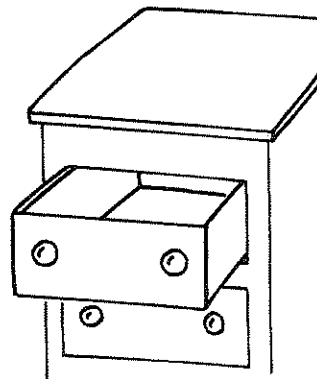
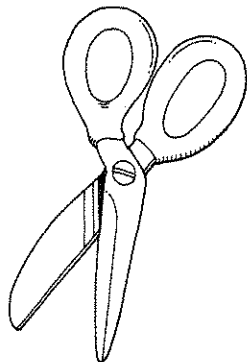

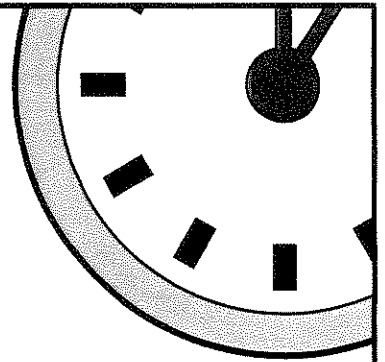

Minute 36

Name _____

For Numbers 1–5, either circle the action verb or underline the linking verb in each sentence.

1. The roller coaster raced around the track.
2. A snowman melts in the sunshine.
3. Natalie was fourteen years old.
4. Pete and Hank built a go-cart from scraps of wood.
5. He is very tired.

For Numbers 6–10, write a sentence that includes an action verb.

6. It is snowy outside.

The snow _____

7. It is nice weather in the city today.

The sun _____

8. My friend and I had fun at the concert.

My friend and I _____

9. Lisa is tired.

Lisa _____

10. I am hungry.

My stomach _____

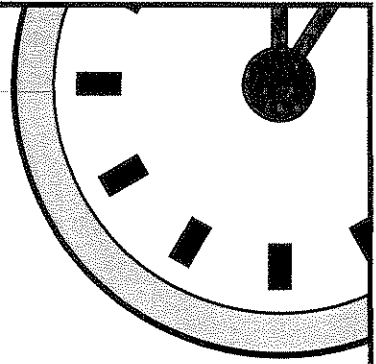

Minute 37

Name _____

Write *H* if the verb in the sentence helps another verb or expresses time or mood. Write *L* if the verb links two ideas together.

1. I will run to the store quickly. _____
2. The capital of the United States is Washington, D.C. _____
3. The peaches are ripe. _____
4. The bananas will ripen if you store them in a paper bag. _____
5. They should walk to the store rather than drive. _____
6. He is taking his time. _____
7. The shoes were in the closet. _____
8. He can store his shoes in the closet. _____
9. The evening sky is beautiful. _____
10. The chef seems capable. _____

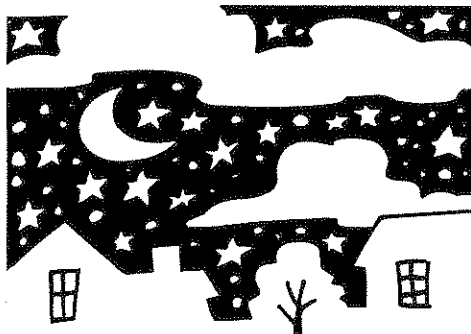

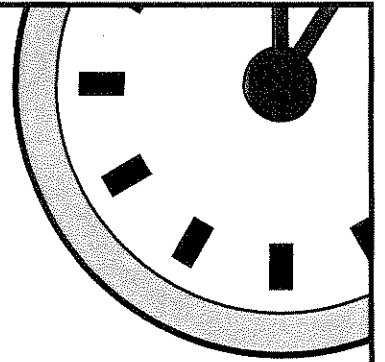
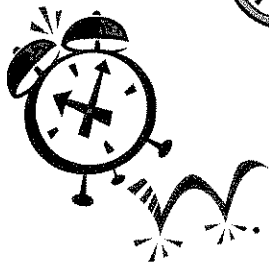

Minute 38

Name _____

For Numbers 1-5, write the past tense form of each verb.

1. run _____
2. dive _____
3. freeze _____
4. walk _____
5. think _____

For Numbers 6-10, add *-ing* or *-ed* to the verb to correctly complete each sentence.

6. Janice is _____ the crumbs that fell on the floor.
sweep
7. When the glue has _____, we can take home our projects.
dry
8. The drummers are _____ in a parade this Saturday.
march
9. All of the athletes _____ after completing the race.
stretch
10. The fireworks _____ in the sky.
explode

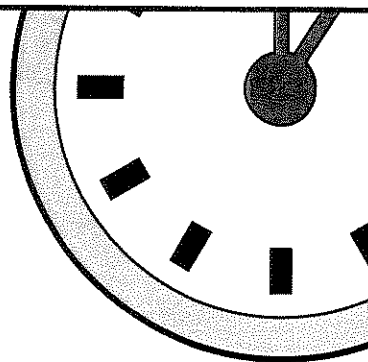
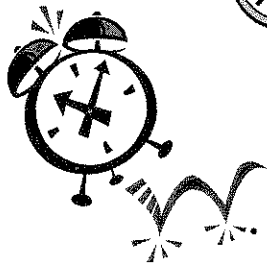

Minute 39

Name _____

For Numbers 1-5, circle the correct verb to complete each sentence.

1. Where did you (lay/lie) the pencils?
2. It feels good to (lie/lay) down after a long bike ride.
3. Jimmy likes to (set/sit) out all his materials before he paints.
4. Mom honked the car horn as we (passed/past) the school.
5. The class will (rise/raise) money to take a field trip.

For Numbers 6-10, write Yes if the correct verb is used for each sentence. Write No if it is not.

6. We passed time by playing road trip games. _____
7. The bread will raise to the top of the pan. _____
8. I lie the presents on the table. _____
9. The vase sits on the mantle in our living room. _____
10. After you're finished reading the newspaper, sit it on the shelf. _____



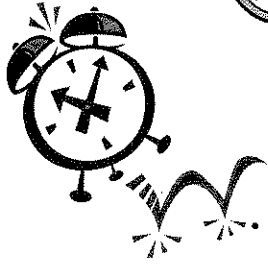

Minute 40

Name _____

Circle the correct verb form to complete each sentence.

1. Candice (expect/expects) her team to win the competition.
2. The tired old dog (flop/flops) down on the kitchen floor.
3. There (was/were) too many students standing in the hallway.
4. In my grandfather's attic (is/are) dozens of old cameras.
5. Blanca, my older sister, (plan/plans) to attend Stanford University in the fall.
6. The flesh of the fruit (is/are) tender and juicy.
7. Harry (wish/wishes) his best friend would get well soon.
8. The teacher (eat/eats) lunch in the school cafeteria along with his students.
9. Among the top three tennis players in the world (is/are) two Europeans and one Canadian.
10. The adventurous climber (use/uses) ropes and other safety devices as she climbs the face of the cliff.

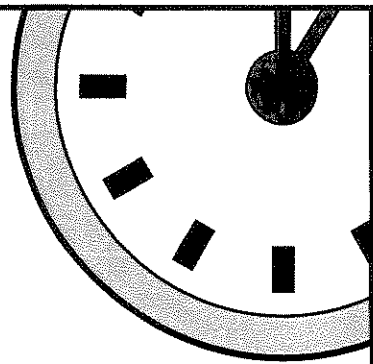

Minute 41

Name _____

For Numbers 1–5, circle the descriptive adjective(s) in each sentence.

1. The awkward foal returned to the barn.
2. The magic carpet flew over the city.
3. The baker delivered delicious cookies for the teachers' meeting.
4. A tiny, black puppy romped in the white snow.
5. The dirty, smelly shoes were left on the step.

For Numbers 6–10, use an adjective from the box to best complete each sentence. Use each adjective only once.

demanding
beautiful

little
unpredictable

green
mashed

6. The _____ volcano finally erupted last week.
7. Ginny is saving her money to buy a _____ necklace.
8. The _____ passenger asked the driver to listen to his directions.
9. Kevin's _____ brother likes _____ balloons.
10. The cafeteria is serving _____ potatoes for lunch today.

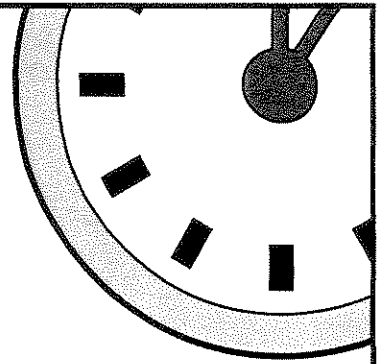
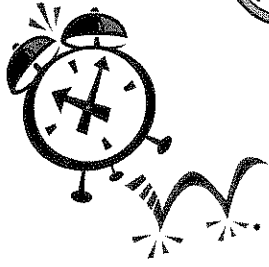

Minute 42

Name _____

Replace the underlined word in each sentence with a descriptive adjective from the box that means about the same thing.

narrow	generously	dangerous	exquisite
speedy	plump	hilariously	contented
level	humble	helpful	immense
diamond	playful	unintelligent	kind

- The nice boy picked up the fallen books. _____
- The bad snake chased a rat. _____
- She looked at the pretty jewels in the glass case. _____
- The fast car raced along the highway. _____
- A fat cow slowly chewed hay. _____
- The happy girl ate an apple as she waited for her friend. _____
- The flat road stretched as far as we could see. _____
- Alex is a good friend who always listens. _____
- The big umbrella kept me dry. _____
- A funny seal played in the water. _____

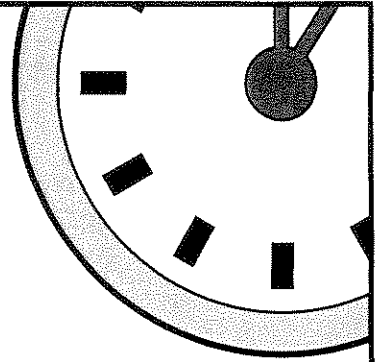
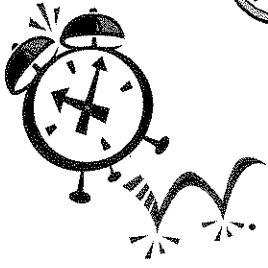

Minute 43

Name _____

Circle the correct form of the adjective.

(Hint: Generally, add *-er* to most one-syllable adjectives to show comparison. Use *more* for adjectives with two- or more syllables.)

1. smoother more smooth

2. fresher more fresh

3. generaler more general

4. difficulter more difficult

5. jealouser more jealous

6. kinder more kind

7. lighter more light

8. memorabler more memorable

9. quicker more quick

10. helplesser more helpless

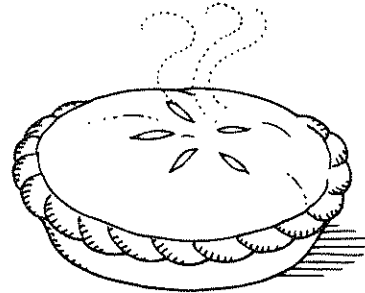

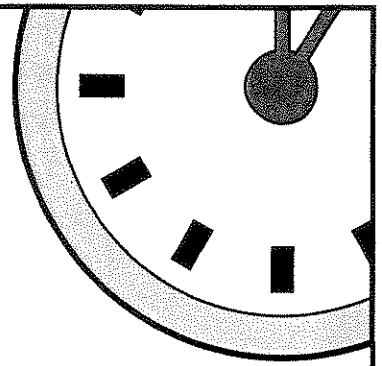

Minute 44

Name _____

For Numbers 1-5, circle the correct adjective to complete each sentence.

1. Mint chocolate chip is the (good/best) ice cream flavor available.
2. A broken leg is (worse/more bad) than a broken fingernail.
3. Sharice picked (most/more) berries than Frank.
4. That movie was (less/least) exciting than the one we saw last week.
5. The sour pickles were (more worse/worse) than the lemons.

For Numbers 6-10, write the comparative and superlative form of each adjective.

Adjective	Comparative	Superlative
Ex. high	higher	highest
6. flat	_____	_____
7. brave	_____	_____
8. strong	_____	_____
9. calm	_____	_____
10. lean	_____	_____

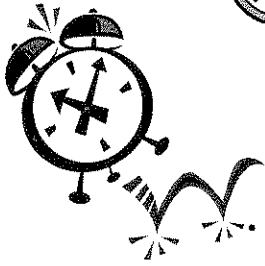

Minute 45

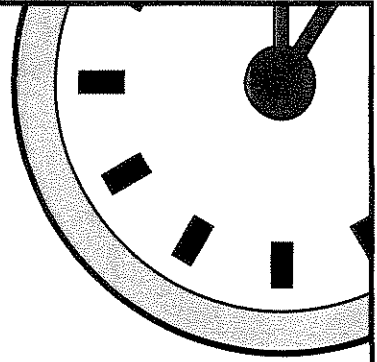

Name _____

For Numbers 1–5, circle the adverb in each sentence.
(Hint: An adverb is a word that tells *how*, *when*, or *where* something happens.)

1. The Bulldogs played mightily but lost the soccer game.
2. The boulder landed heavily on the valley floor.
3. Trisha waited eagerly while her mother paid for the new dress.
4. Measure exactly how long the shelf should be.
5. The spinning top twirled crazily before falling off the table.

For Numbers 6–10, circle the correct use of *good* or *well* in each sentence.
(Hint: Use *good* as an adjective. Example: She is having a good day. Use *well* as an adverb. Example: She draws well.)

6. The chocolate cupcakes smell (good/well).
7. Kate played (good/well) in the game.
8. The knots in the line look (good/well).
9. Nadia danced (good/well) at her ballet recital.
10. Hee Jin did (good/well) on her science test.

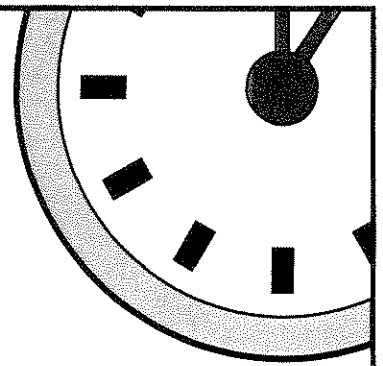
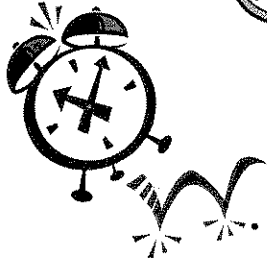

Minute 46

Name _____

Write *how, when, where, how often, or to what degree* to tell what the underlined adverb describes.

1. The students worked quickly. _____
2. Drake visits his grandmother frequently. _____
3. Mr. Rodriguez finds teaching extremely enjoyable. _____
4. Grace will enter middle school next year. _____
5. You left your lunch there on the table. _____
6. I am leaving today for summer camp. _____
7. Julie worked carefully on her egg painting. _____
8. The doctor pressed gently on Sara's broken arm. _____
9. Ms. Muldoon checks our homework daily. _____
10. Josh was very grateful when his wallet was found. _____

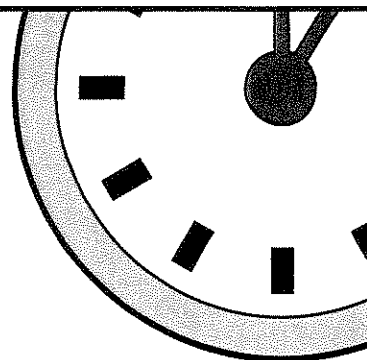

Minute 47

Name _____

For Numbers 1–10, write the comparative and superlative form of each adverb.
(Hint: Use either *-er* and *-est* or *more* and *most*)

Adverb	Comparative	Superlative
1. fast	_____	_____
2. quietly	_____	_____
3. early	_____	_____
4. often	_____	_____
5. slowly	_____	_____
6. far	_____	_____
7. near	_____	_____
8. carefully	_____	_____
9. soon	_____	_____
10. gracefully	_____	_____

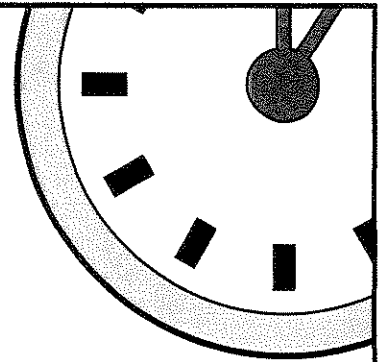
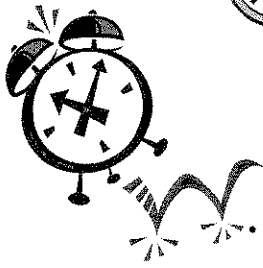

Minute 48

Name _____

For Numbers 1–5, circle the correct form of the adjective to complete each sentence.

(Hint: Adjectives that end in *-er* compare two things, and adjectives that end in *-est* compare more than two things.)

1. Mrs. Klein's math class is (more hard/harder) than Mr. Brown's.
2. My scoop of ice cream is (larger/largest) than Tommy's.
3. The drum is (more louder/louder) than the guitar.
4. Danielle is the (more smaller/smallest) of the triplets.
5. Of all the students in the class, Gabriel is the (most tallest/tallest).

For Numbers 6–10, write the comparative or superlative form of each adjective.

Adjective	Comparative	Superlative
6. good	better	_____
7. bad	_____	worst
8. little	less	_____
9. few	_____	fewest
10. much	more	_____

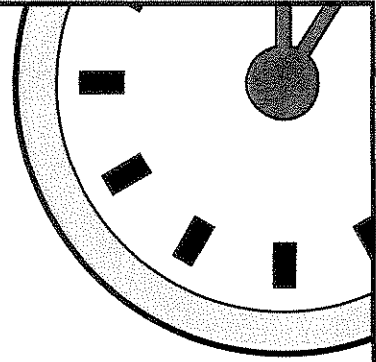

Minute 49

Name _____

Circle the word that the underlined adverb modifies.

(Hint: An *adverb* can modify a verb, an adjective, or another adverb.)

1. We hesitantly ate the okra Mom served us.
2. The mother chimpanzee held her baby snugly against her chest.
3. We often go to the swimming pool at the community center.
4. Contests are held locally for anyone who is interested.
5. Javier thoughtfully considered his options before deciding.
6. The strangely shaped teddy bear sat awkwardly on the shelf in the toy store.
7. The guests spoke loudly in the dining room.
8. Sasha marched purposefully to the teacher's desk.
9. Mrs. Westland is very generous.
10. I will remember this vacation forever.

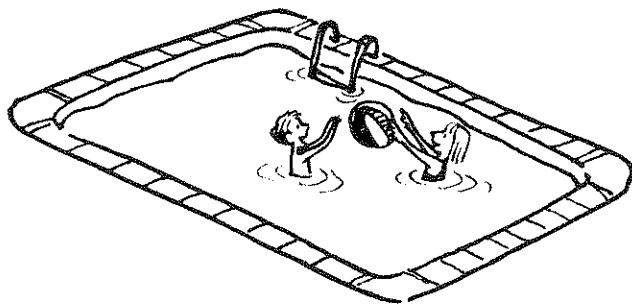

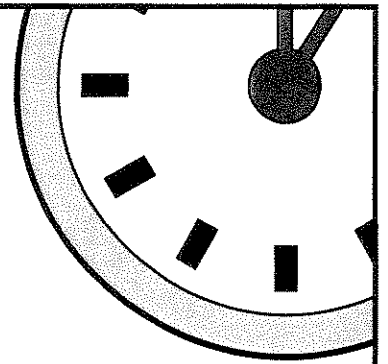
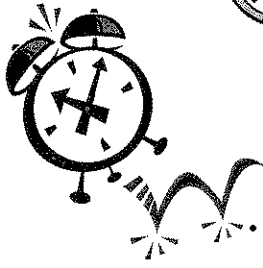

Minute 50

Name _____

Write *adj* if the word underlined is an adjective or *adv* if the word underlined is an adverb.

1. Runs quickly _____

2. Playful puppy _____

3. Gaze longingly _____

4. Cold water _____

5. Eat frequently _____

6. Speak quietly _____

7. Quiet students _____

8. Fried chicken _____

9. Hard rock _____

10. Hardly working _____

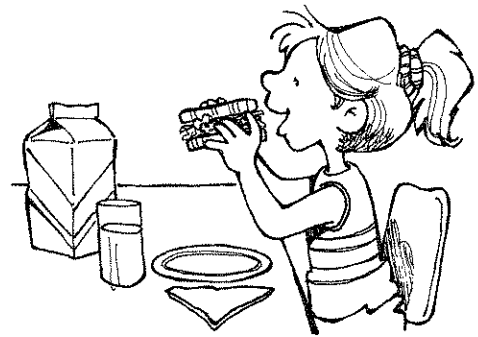
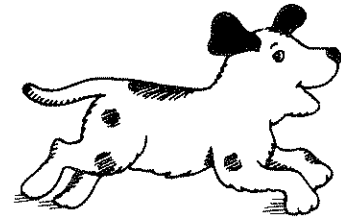

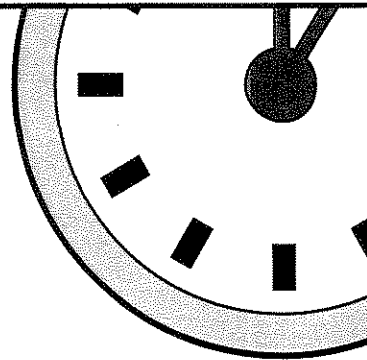

Minute 51

Name _____

Circle the word(s) the underlined adjective or adverb modifies.

1. The brilliant blue chair is the most uncomfortable seat in the room.
2. The moon shone brightly over the majestic mountains.
3. We had an incredible view from the window of our cabin.
4. The drum beat a contagious rhythm.
5. Mom says the washing machine runs constantly.
6. There were subtle signs Ernie was planning a party.
7. Wendy effortlessly climbed the rock wall.
8. The player bounced the ball repeatedly before taking a shot.
9. Our group worked hard on the science fair project.
10. Zack is the most experienced traveler in the group.

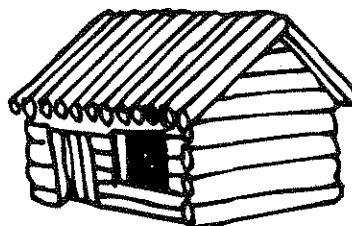

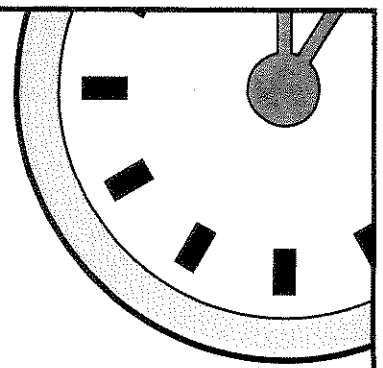

Minute 52

Name _____

For Numbers 1–5, circle the two prepositions in each sentence.

(Hint: A *preposition* shows a relationship of a noun or pronoun to another word in the sentence and often tells where, what kind, when, or how. Example: I ran *along* the shore.)

1. Roland had to choose between the bearded dragon and the green iguana as his pet.
2. The paleontologist with the white gloves placed the fossil inside the heavy glass case.
3. The two girls looked at each other across the table.
4. Our football team celebrated at a restaurant after winning the championship game.
5. The willow tree beside the brook up the road is my favorite place to read.

For Numbers 6–10, use a preposition from the box to correctly complete each sentence. Use each preposition only once.

inside

beneath

with

since

near

6. The students put their lunch boxes _____ their lockers.
7. The cave _____ the mouth of the river was full of bats.
8. Lava forms well _____ the earth's surface.
9. The little boat _____ a striped sail won the race.
10. _____ she discovered stamp collecting, Sara has given up gardening.

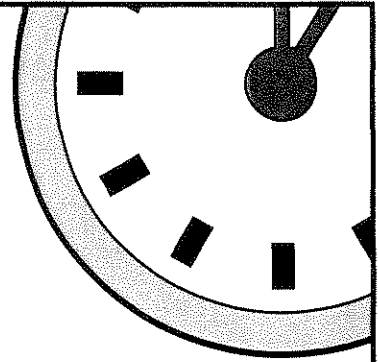
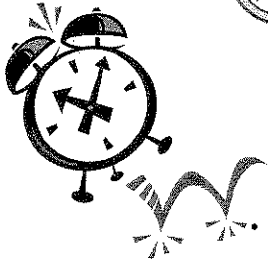

Minute 53

Name _____

For Numbers 1–5, write *between* or *among* to correctly complete each sentence.

(Hint: Use *between* when you are referring to two people, items, or ideas; use *among* when referring to three or more.)

1. The contest is _____ Shana and Wren.
2. Who _____ you is the greatest warrior?
3. I had to choose _____ chocolate chip and vanilla ice cream.
4. Isabella finished her homework _____ seven and eight o'clock.
5. Voters will decide _____ the Democrats and the Republicans.

For Numbers 6–10, write *Yes* if the correct preposition is used. Write *No* if it is not.

6. How many states are among California and Texas? _____
7. Quan, Fran, and David are among the favorites to win the golf tournament. _____
8. Mrs. Sanger will choose among the Mighty Mongrels and the Laughing Labradors for the winner of the talent show. _____
9. My coach is the woman standing between the two men in red jackets. _____
10. Choosing a book between so many great titles is difficult. _____

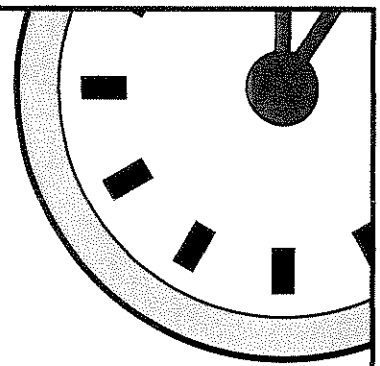
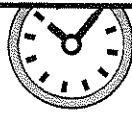

Minute 54

Name _____

Circle either *a* or *b* to show which underlined phrase is the prepositional phrase in each sentence.

(Hint: A prepositional phrase begins with a preposition and ends with a noun.)

1. In Australia, kangaroos can be found roaming in the wild.
a b
2. The school counselor encouraged us to think about our future career choices.
a b
3. Jimmy had trained for the X Games in snowboarding.
a b
4. Benjamin Franklin had many accomplishments as a great American leader.
a b
5. In 1958, the United States launched its first successful satellite, *Explorer 1*.
a b
6. Now happy, Carla skipped off with her best friend, Janelle.
a b
7. In live concert, Ian's favorite band was even better.
a b
8. Pluto takes more than 247 years to revolve around the sun.
a b
9. Tropical rain forests have the greatest variety of plant species on earth.
a b
10. Nigel and Jack decided to cook macaroni and cheese for lunch.
a b

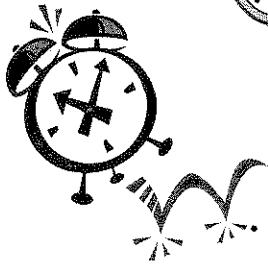

Minute 55

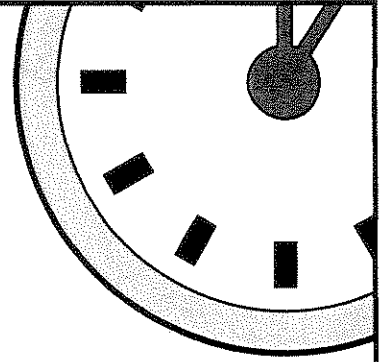

Name _____

For Numbers 1–5, use at least one prepositional phrase found in the box to write a sentence.

about four o'clock	across the street	in my space
against the wall	along the path	of the crowd
around the bend	behind the door	over the hill

1. _____
2. _____
3. _____
4. _____
5. _____

For Number 6–10, circle the prepositional phrase in each sentence.

6. She put the present inside the box and mailed it.
7. "Please put all papers on my desk," said Mrs. Larmer.
8. She could barely see through the window.
9. Will you go to the party or will you go home?
10. Sarah walked on the sidewalk, facing traffic.

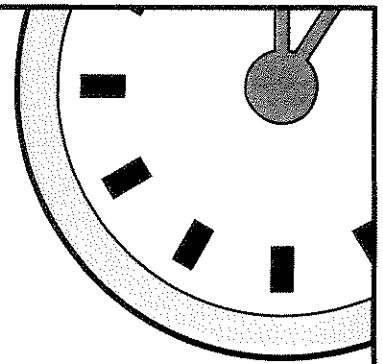
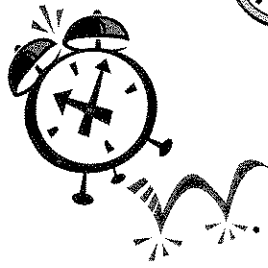

Minute 56

Name _____

For Numbers 1-5, write the article *a* or *an* to correctly complete each phrase.
(Hint: Use *a* before a word that begins with a consonant sound. Use *an* before a word that begins with a vowel sound.)

1. _____ fox and her babies
2. _____ orange and a banana
3. _____ honest answer
4. _____ busy city
5. _____ ancient scroll

For Numbers 6-10, write the article(s) that best completes each sentence.
(Use *a*, *an*, or *the*.)

6. Melanie's team, the Stingrays, just scored three goals to win _____ championship hockey game.
7. They played in _____ championship tournament all week and had to beat _____ good team to make it to the finals.
8. _____ game was held on Sunday, March 9, 2008, at Madison Square Garden in New York City.
9. Billy saw _____ opportunity to score in the last minutes of _____ second period and succeeded.
10. It was _____ great victory and _____ honor to be declared the best team in the country.

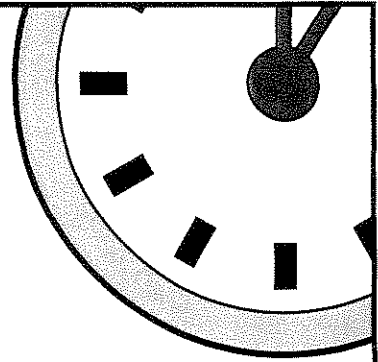
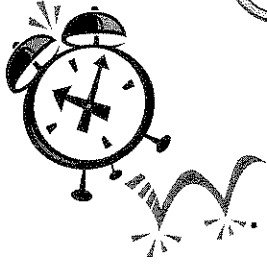

Minute 57

Name _____

For Numbers 1–5, circle the correct conjunction to complete the sentence.
(Hint: A *conjunction* is a word that joins words or groups of words. It can show togetherness or contrast. Example: Patricia *and* Mark went to the restaurant, *but* Mark did not eat.)

1. The rain began, (yet/since/so) the ceremony was moved inside.
2. Albania is a small country, (and/since/or) it is one of Europe's poorest.
3. Sound travels fast. (Since/However/So), light travels faster.
4. Sidney Crosby was born in Dartmouth, Nova Scotia, (so/although/but) grew up in Cole Harbour.
5. Ancient Sumerians developed cuneiform, (and/or/since) Ancient Egyptians developed hieroglyphics.

For Numbers 6–10, write a conjunction from the box to best complete each sentence. Do not use a conjunction more than once.

and yet so but since or although because

6. The new house was complete, _____ it had no furniture.
7. Patty _____ Pricilla are sisters.
8. The cafeteria served hamburgers _____ not hot dogs.
9. My friend asked if I wanted to see either a comedy _____
an action movie.
10. _____ the clown was somewhat funny, he also annoyed me.

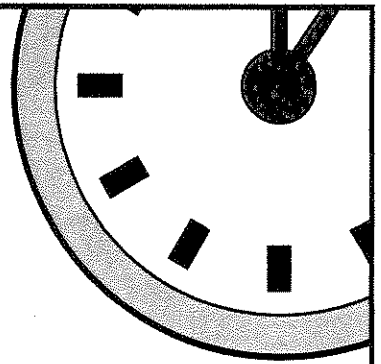

Minute 58

Name _____

For Numbers 1–4, rewrite the two sentences as a single sentence. Use a conjunction to join them.

(Hint: Eliminate words that repeat, and then combine the rest of the words to shorten sentences and save time.)

1. I will go to the park. I will get Jerome.

2. Veronica enjoys ballet. She doesn't like ballet recitals.

3. The guitarist played a quiet ballad. The singer hummed softly.

4. The Internet is a good source of information. The Internet also provides entertainment.

For Numbers 5–10, write *Yes* if the example is a compound sentence. Write *No* if it is not.

5. Ponce de Leon explored the southeast coast of North America. _____

6. I will take a weight training class and an aerobics class. _____

7. He and I will take a trip down to San Francisco in the fall or winter. _____

8. Alexander Graham Bell invented the telephone. _____

9. The teachers were ready for the start of school, but the students were not ready for summer to end. _____

10. Icicles hung from the trees, and children made snowmen in the yard. _____

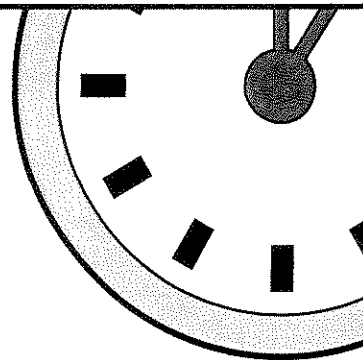
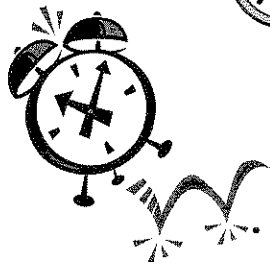

Minute 59

Name _____

For Numbers 1–5, underline the appositive in each sentence. Circle the noun or pronoun that it describes.

(Hint: An *appositive* identifies or renames the words before it. Example: Our teachers, *Mr. Jones and Ms. Liddell*, went to a conference on Friday.)

1. Jake, the soccer star, is the most popular boy in school.
2. Dr. Williams, my pediatrician, checked my reflexes with a small rubber hammer.
3. Our class finished reading Charlie and the Chocolate Factory, Roald Dahl's masterpiece, last week.
4. Is that your sister, Hannah, with the ponytail?
5. The Indianapolis 500 race, the epitome of American racing, was first held in 1911.

For Numbers 6–10, write *D* if the underlined portion is a dependent clause. Write *I* if the underlined portion is an independent clause.

(Hint: A *dependent clause* does not express a complete thought and is not a complete sentence on its own. An *independent clause* expresses a complete thought and could stand alone as its own sentence.)

6. Come to my house, and we will start on our science project. _____
7. All stations will televise the president's speech when he speaks. _____
8. My brother will drive us to the movies after he is finished with work. _____
9. The professor announced an exam, and students scrambled to study. _____
10. Troy will enter the yodeling contest if Maggie enters. _____

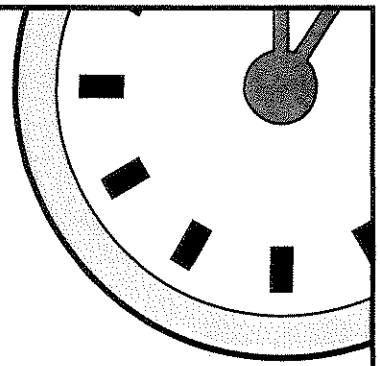
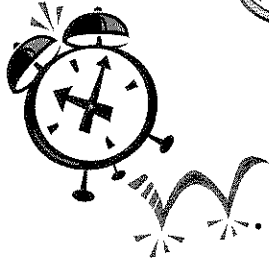

Minute 60

Name _____

Underline the prepositional phrase(s) in each sentence.
(Hint: The remaining words should still make a complete sentence.)

1. The entire class went to the performance except Charles.
2. Sailors use the stars to find their location on earth.
3. Groovy girls in the 1960s wore their hair very long and very straight.
4. Christopher Columbus landed in the Bahamas.
5. New Year's Day is a big celebration for our family.
6. Many companies in our community allow employees time off to vote.
7. Percussion instruments make sound when they are struck by the musician.
8. She closed the book and walked out of the library into the bright sunshine.
9. Nate grew up on a farm in West Virginia.
10. The United Nations was founded in 1945, after World War II ended.

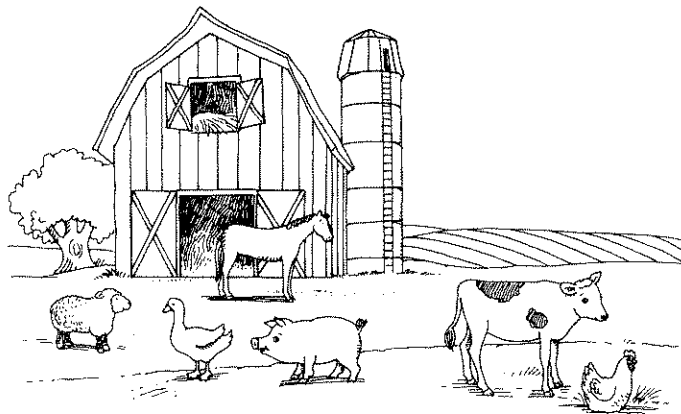

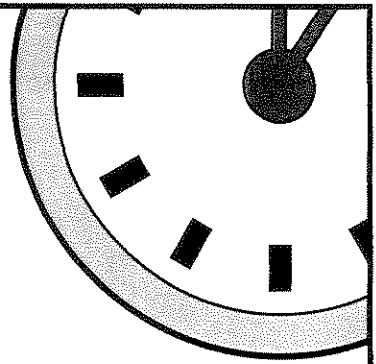

Minute 61

Name _____

For Numbers 1–5, write the article *a* or *an* to correctly complete each phrase.

1. _____ kneepad
2. _____ high-flying kite
3. _____ biology class
4. _____ hour
5. _____ once-in-a-lifetime opportunity

For Numbers 6–10, circle the article that correctly completes each sentence.

6. Jefferson Elementary School held three fundraisers to buy new computers for (the/an) technology lab.
7. If you have any questions about (an/a) problem on the math homework, please write which problem number it is in your journal.
8. Preston displayed (an/the) coin he found at an old ghost town.
9. (An/A) G-rated movie is appropriate for all ages.
10. Janet wore (a/an) orange dress with flowers on the sleeve.



Minute 62

Name _____

For Numbers 1–5, circle the conjunction that correctly completes each sentence.

1. I say I'm busy, (yet/and/or) I always find myself saying yes when people ask for help.
2. I turn my ringer off at night (because/however/yet) I don't want to be disturbed.
3. The phone not only woke me up (and/yet/but also) woke up my sister.
4. Bring either a pen (but also/yet/or) a pencil.
5. I bought a new skirt (however/and/but also) a new sweater.

For Numbers 6–10, circle the conjunctions that join two or more things. Underline the conjunctions that contrast two or more things (or that change the direction of the sentence).

6. We looked at the take-out menus and circled our food choices.
7. We always order fried rice, so this time we tried something different.
8. Do you want noodles or stir-fry?
9. Gemma likes soy sauce and pepper on all of her food.
10. Daniel eats a lot, although he always regrets it later.

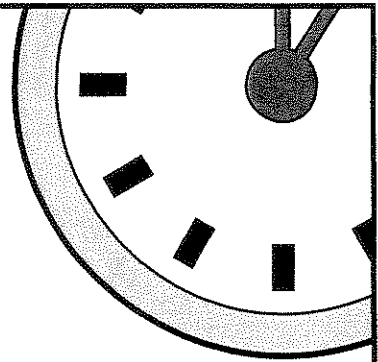

Minute 63

Name _____

For Numbers 1–6, write *Yes* if the example is a compound sentence. Write *No* if is not.

- 1. Valerie will visit Ireland to view the Book of Kells , but she will not have time to tour the countryside. _____
- 2. Janet cut the cake, and we all sang "Happy Birthday." _____
- 3. Jay and Luis felt upset when their soccer team lost. _____
- 4. Air pollution is harmful to plants and to animals. _____
- 5. Jennifer will join the chorus, and she will also take piano lessons this year. _____
- 6. Chinese Americans and Korean Americans often celebrate the lunar New Year. _____

For Numbers 7–10, rewrite the sentences as a single sentence.

- 7. At summer's end, many students pack up for college. They drive to their campuses.

- 8. The pizza was cut into eight pieces. It was all gone shortly thereafter.

- 9. The athletes in the triathlon run. The athletes also bike for miles. They also have to swim.

- 10. I know how to ride a bicycle. I also can ride a unicycle. My friend knows how to ride a bicycle and unicycle too.

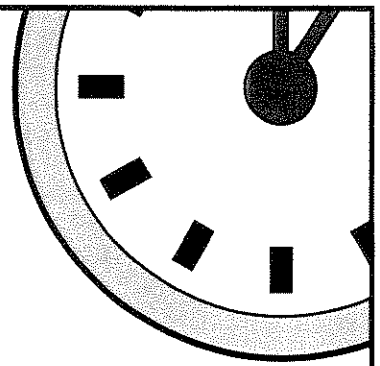

Minute 64

Name _____

For Numbers 1-5, write a sentence using each of the appositives below.

my favorite book	a movie released last week
my hardest subject in school	the tiny kitten
my sister's friend	

1. _____
2. _____
3. _____
4. _____
5. _____

For Numbers 6-10, write *D* if the underlined portion is a dependent clause. Write *I* if the underlined portion is an independent clause.

6. My little sister goes to the preschool where Miss Wendy works. _____
7. Patrick earned fourteen dollars by mowing lawns, and he planned to spend it on video games. _____
8. It was impossible to ignore the terrible stench that came from the hallway. _____
9. The tree is withering and losing its leaves already. _____
10. Brianna walked to Nancy's house, and together they went to the mall. _____

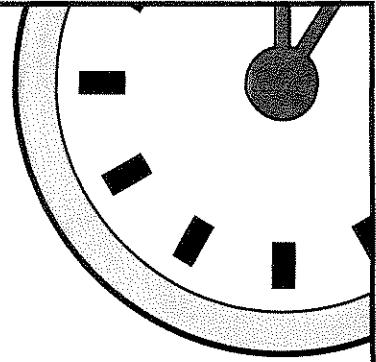
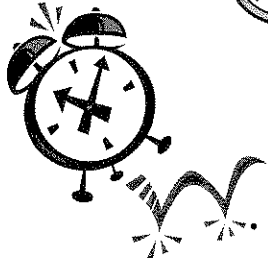

Minute 65

Name _____

Add another word to the beginning or the end of each word below to create a compound word.

1. air _____
2. back _____
3. brain _____
4. day _____
5. dog _____
6. heart _____
7. counter _____
8. down _____
9. earth _____
10. man _____

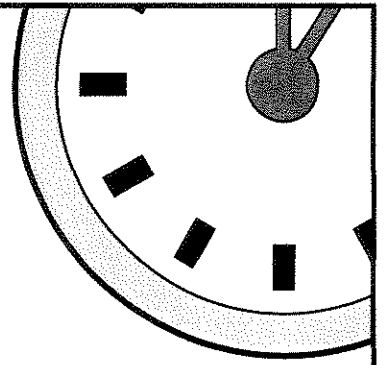
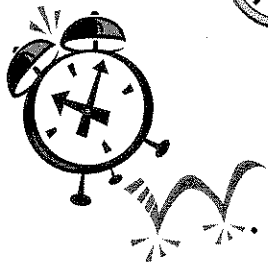

Minute 66

Name _____

Write a synonym for each underlined word.

1. The loud blast from the car horn shook him awake. _____
2. Jack refused to be afraid of a tiny spider. _____
3. You are out if you step outside the boundary. _____
4. Dr. Garrison was very concerned about Amber's high fever. _____
5. The level of the water continued to rise. _____
6. After baseball practice, my uniform is dirty. _____
7. The sunset was pretty. _____
8. A bright light filled the auditorium and the show began. _____
9. The cornfields seem to go on forever. _____
10. It is best to fly a kite on a windy day. _____

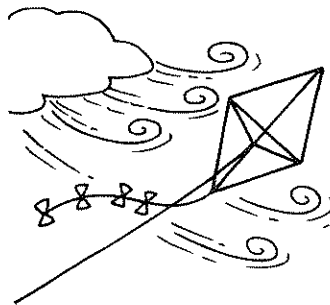

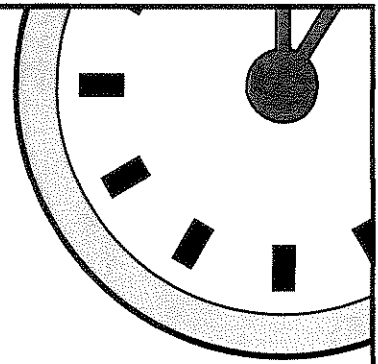

Minute 67

Name _____

Write a synonym for each word.

1. smart _____
2. narrow _____
3. apart _____
4. argue _____
5. center _____
6. awful _____
7. shy _____
8. smelly _____
9. cute _____
10. path _____

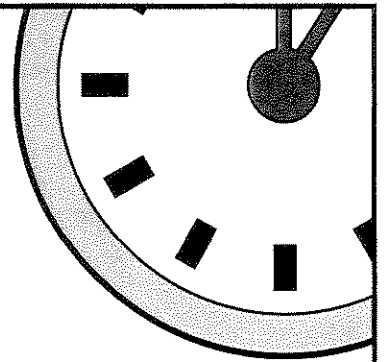

Minute 68

Name _____

Draw a line to match each word with its antonym.

- | | | | |
|--------------|---|---|--------------|
| 1. part | • | • | ancient |
| 2. praise | • | • | whole |
| 3. modern | • | • | slow |
| 4. ceiling | • | • | rough |
| 5. speedy | • | • | criticize |
| 6. protected | • | • | subtract |
| 7. add | • | • | intermittent |
| 8. constant | • | • | unsheltered |
| 9. asleep | • | • | floor |
| 10. smooth | • | • | awake |

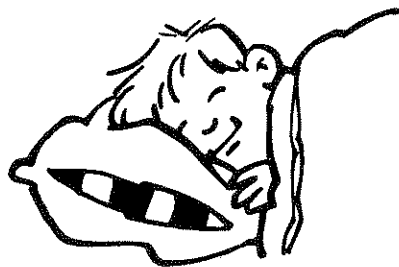

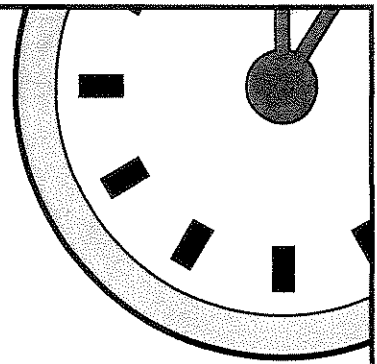
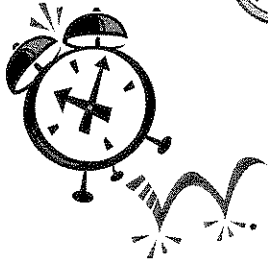

Minute 69

Name _____

Write an antonym for each word.

1. tardy _____
2. new _____
3. rotten _____
4. scarce _____
5. flat _____
6. locked _____
7. sink _____
8. lazy _____
9. empty _____
10. dishonest _____

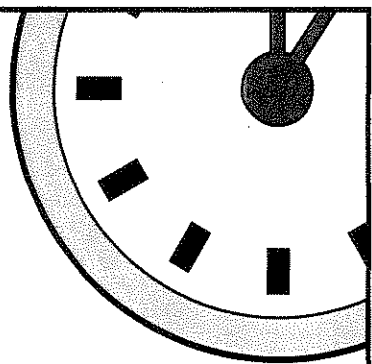

Minute 70

Name _____

For each sentence below, use the other form of the underlined homograph to write a new sentence.

(Hint: Homographs are words that are spelled the same, but have different meanings and often have different pronunciations.)

1. Close the screen door to keep the mosquitoes out.

2. Barry caught the biggest bass I've ever seen.

3. We watched the dove hover over her babies.

4. Where will we house the hamster?

5. The snake prefers to eat live mice.

6. Mrs. Billings had to separate the two mischievous girls.

7. The weather forecaster projects rain for the weekend.

8. How can you mend a tear in the tent?

9. What is your address?

10. Johnny will present the award to Michelle.

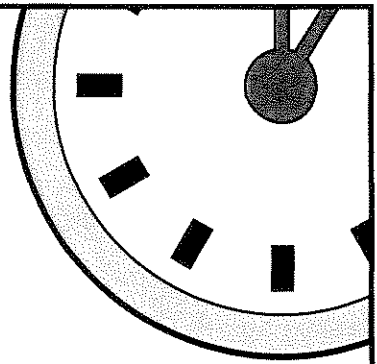
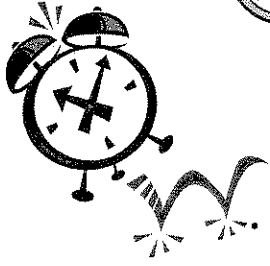

Minute 71

Name _____

Write the correct homophone to complete each sentence.

(Hint: *Homophones* are words that sound the same but are spelled differently and have different meanings.)

1. Vera _____ seven cupcakes.
ate eight
2. What type of _____ do you like to have for breakfast?
cereal serial
3. We _____ Tony and Elaine talking about the birthday party.
herd heard
4. The _____ efficiently cleaned each room.
maid made
5. The actor studied her lines for the _____ of Juliet.
roll role
6. Our school's _____ wears a tie every day.
principal principle
7. The class gave a loud _____ when the teacher announced a quiz.
groan grown
8. The teacher's helper _____ around the papers.
passed past
9. I can't _____ to watch.
bear bare
10. The boat appeared out of the _____.
mist missed

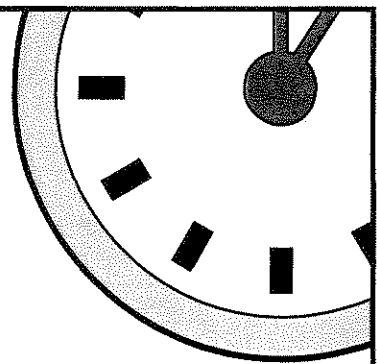

Minute 72

Name _____

Circle the correct word in parentheses to complete each sentence.

1. Irena went (too/to) the museum.
2. Brad and I saw (two/too) elk walking through the woods.
3. Rene had chili for lunch, (to/too).
4. (Too/Two) many students packed into the bus.
5. (There/They're) are no seats left.
6. Mary and Kristine went to get (their/they're) backpacks.
7. (They're/Their) winning the game.
8. (It's/Its) Pilar's turn to play.
9. When (your/you're) finished with your dinner, please clear your plate.
10. The whale created a huge splash when it smacked (its/it's) fluke on the water.

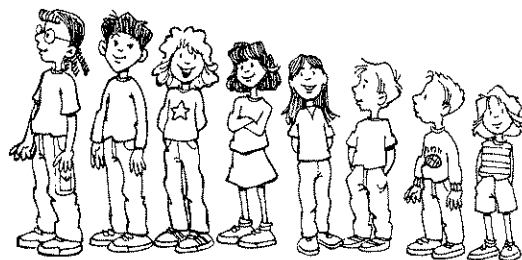
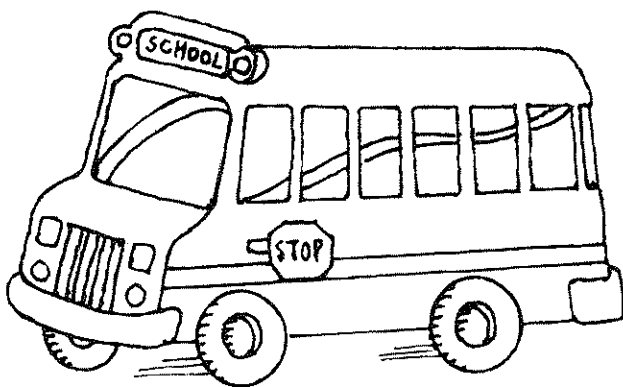

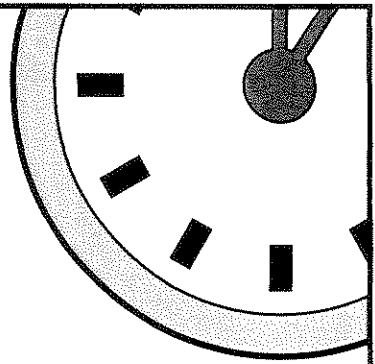

Minute 73

Name _____

Write a synonym and an antonym for each word.

Word	Synonym	Antonym
1. tired	_____	_____
2. similar	_____	_____
3. noisy	_____	_____
4. receive	_____	_____
5. comical	_____	_____
6. increase	_____	_____
7. stroll	_____	_____
8. equal	_____	_____
9. valiant	_____	_____
10. grief	_____	_____

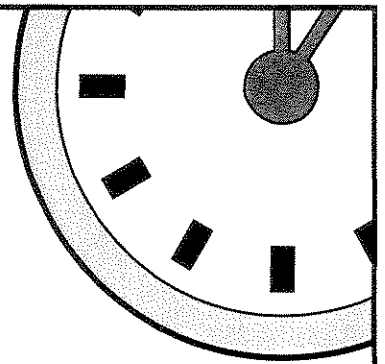

Minute 74

Name _____

For Numbers 1-5, write the homograph to complete each sentence.
(Hint: The word is used in the sentence.)

1. Kylie will present Bridget with a _____.
2. The nurse wound the bandage around the _____.
3. We have one minute to find the _____ details.
4. The contract states Harvey must not _____ any contagious diseases.
5. Troops will not desert the army in the _____.

For Numbers 6-10, complete each sentence with a homophone from the box.

course/coarse

kernel/colonel

feet/feat

night/knight

allowed/aloud

6. Deanne ran the _____ without tipping any hurdles.
7. Only one _____ was left in the popcorn popper.
8. It was an incredible _____ to climb the rock wall.
9. The _____ stormed the castle to save the damsel in distress.
10. Papa _____ me to use his fishing rod.

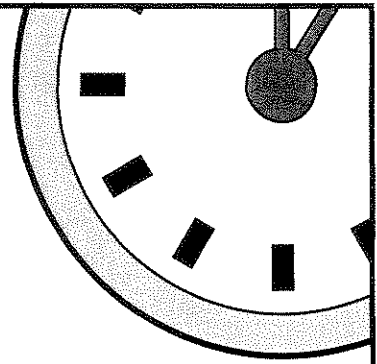

Minute 75

Name _____

Write **Yes** if the sentence is written correctly. Write **No** if it is not.

(Hint: Negative words include *never, no, nobody, not, nowhere*, as well as *barely, hardly, scarcely*. They also include any contractions with the word *not*.)

1. I don't got no gum. _____
2. He won't want nothing to drink. _____
3. They have not had hardly anybody over to their house. _____
4. Stephanie don't never take the bus. _____
5. The gardener won't water the plants when it's night. _____
6. Mr. Hoff can't barely see anything without his glasses. _____
7. Please don't forget to sign your name. _____
8. Nowhere do they not take that kind of credit card. _____
9. The parents told the children that they wouldn't go to Disneyland on vacation. _____
10. Our dogs, Maple and Sunny, are nowhere to be found. _____



Minute 76

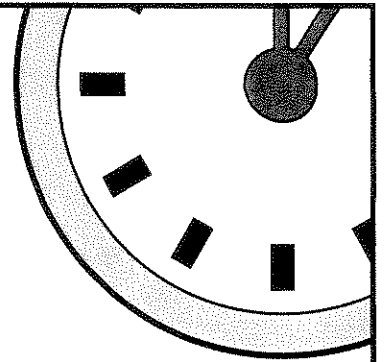

Name _____

For Numbers 1-5, write the two words that combine to make each contraction.

1. they've _____
2. she'd _____
3. I'm _____
4. don't _____
5. hadn't _____

For Numbers 6-10, write the contraction for each set of underlined words.

6. You will become a major league player one day. _____
7. That shirt does not go with those pants. _____
8. Let us go to the library tomorrow. _____
9. Who would like to see a movie tonight? _____
10. Tory will not finish the race. _____

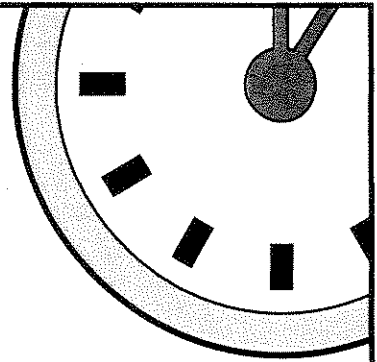
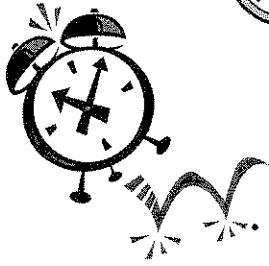

Minute 77

Name _____

For Numbers 1–5, insert commas in the correct places.

1. Pedro please remember to buy milk butter and eggs.
2. Yes I would like French fries with my hamburger.
3. Marie Curie a Nobel Prize winner was a physical chemist.
4. Tornadoes can happen anytime but they are most common between March and July.
5. An insect's body is divided into the head thorax and abdomen.

For Numbers 6–10, write *Yes* if all necessary commas are included and in the correct place. Write *No* if they are not.

6. My aunt Earleen is moving to Austin, Texas. _____
7. "It's time for ballet class", declared Mom. _____
8. On May 6 1937, the Hindenburg burst into flames upon descent. _____
9. Noah quietly asked, "Who is the bus driver?" _____
10. The Statue of Liberty was dedicated on October 28, 1886. _____

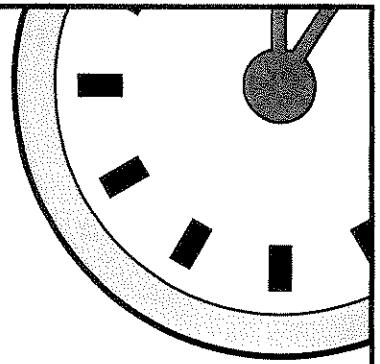
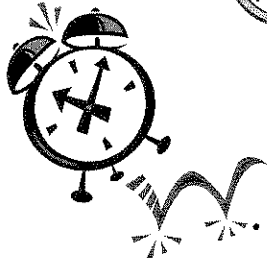

Minute 78

Name _____

Cross out the unnecessary negative words. Write other words on the line to replace them if needed.

1. I don't have no plans for the weekend. _____
2. There isn't no peanut butter in the cupboard. _____
3. I can't hardly believe Shelly would dye her hair purple. _____
4. The water couldn't barely trickle through the thick reeds. _____
5. Hank can't never go to the park. _____
6. There is not hardly any water left in my canteen. _____
7. Why isn't nobody cleaning up the living room? _____
8. I didn't do nothing. _____
9. There isn't nothing to do during the long summer months. _____
10. We aren't never going to do nothing. _____



Minute 79

Name _____

Insert commas to correctly complete each sentence.

1. Tony Hawk was born May 12 1968 in San Diego California.
2. Tokyo Japan is one of the world's most populous cities.
3. Jayden said "You make the best chocolate pudding in the world."
4. The National Baseball Hall of Fame is located in Cooperstown New York.
5. "I watched the funniest program on television" Michael said.
6. Until the bridge is completed we will have to cross at the intersection down the street.
7. The storm clouds began to gather and we ran for cover in the cellar.
8. Quinn will you please answer questions three four and five for us?
9. Keisha the tallest girl in the class balanced herself carefully on a chair and pinned the picture to the bulletin board.
10. My three favorite Olympic sports are swimming basketball and gymnastics.

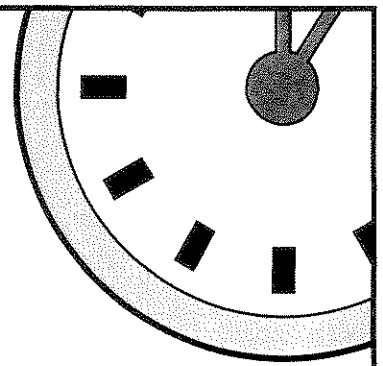

Minute 80

Name _____

Add a prefix to change the meaning of each word, and write its new definition. Use each prefix in the box only once.

anti-	dis-	fore-	inter-	mis-
non-	over-	re-	sub-	trans-

	Root word	Definition	Word with Prefix	Definition
1.	profit	gain	_____profit	_____
2.	eat	consume	_____eat	_____
3.	sight	see	_____sight	_____
4.	handle	manage	_____handle	_____
5.	view	look at	_____view	_____
6.	septic	infection	_____septic	_____
7.	agree	think alike	_____agree	_____
8.	national	of a country	_____national	_____
9.	marine	water	_____marine	_____
10.	port	place	_____port	_____

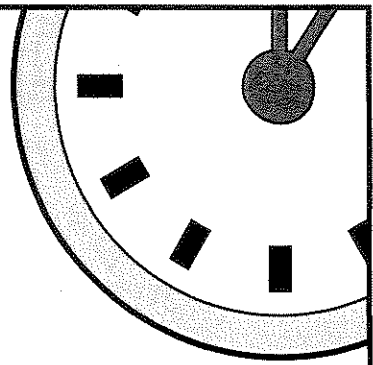
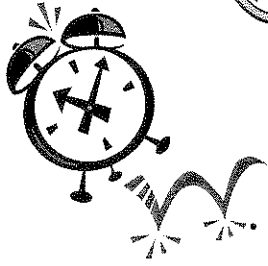

Minute 81

Name _____

Use the definition to add a suffix to each root word. Use each suffix in the box only once.

- | | | | | |
|-------|-------|-------|------|------|
| -ment | -en | -or | -est | -ful |
| -ic | -less | -able | -ous | -y |

Root word	Word with suffix	Definition
1. afford	_____	Can pay for
2. courage	_____	Characterized by bravery
3. hope	_____	Having much faith
4. sharp	_____	Most pointed
5. wood	_____	Rigid
6. poet	_____	Showing characteristics of a poet
7. act	_____	A person who acts
8. move	_____	Act of moving
9. help	_____	Unable to aid
10. fruit	_____	Having the essence of fruit

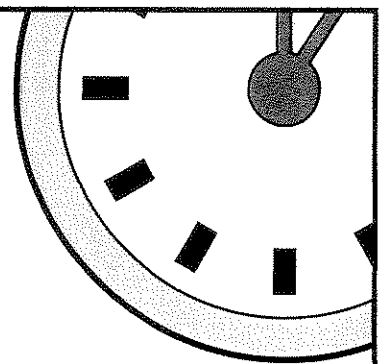

Minute 82

Name _____

Draw a line from the Greek or Latin root to its meaning. Draw another line from the meaning to the sample word.

Root	Meaning	Sample Word
1. dent •	• hear •	• graphic
2. aud •	• see •	• dentures
3. bio •	• trust •	• microscope
4. cred •	• take •	• biology
5. circ •	• tooth •	• vocal
6. graph •	• writing •	• circulate
7. prim •	• call •	• audio
8. voc •	• life •	• primary
9. cap •	• around •	• capture
10. scope •	• first •	• credible

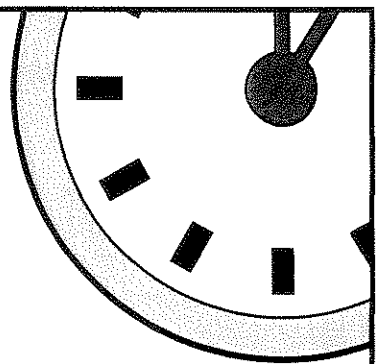

Minute 83

Name _____

For Numbers 1-5, underline the Greek or Latin root(s) in each word.

1. dentist
2. biochemistry
3. circular
4. auditorium
5. telescope

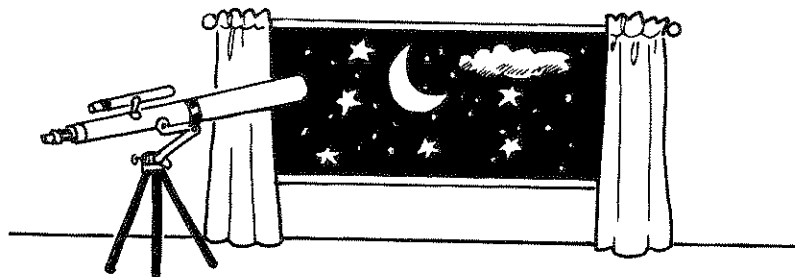

For Numbers 6-10, circle the prefix and/or suffix in each word.

6. antibiotic
7. manageable
8. submerge
9. homeless
10. enjoyment



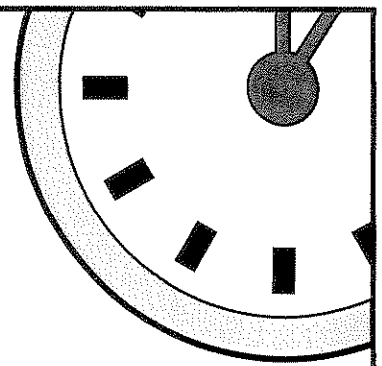
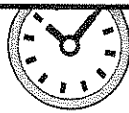
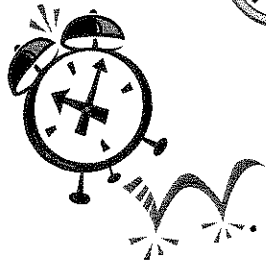

Minute 84

Name _____

For Numbers 1-4, underline the complete subject and circle the complete predicate in each sentence.

1. Babies cry.
2. The swimmers raced to the finish line.
3. The city of Los Angeles hosted the 1984 Olympic Games.
4. A rusty old car sat abandoned on the side of the road.

For Numbers 5-7, write Yes if the group of words is a complete sentence. Write No if it is not.

5. A cool glass of water. _____
6. Soccer practice is every Monday and Wednesday. _____
7. In the morning, after the sun has risen. _____

For Numbers 8-10, insert the correct punctuation at the end of each sentence. Write what type of sentence it is: *declarative*, *interrogative*, *imperative*, or *exclamatory*.

8. What day is it ____ _____
9. Go away ____ _____
10. The humidity weighed heavily on everyone ____ _____

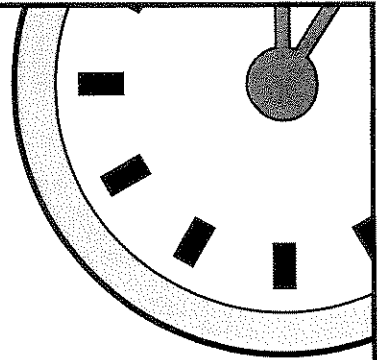
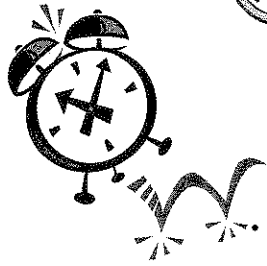

Minute 85

Name _____

For Numbers 1-3, underline the common nouns. Circle the proper nouns.

1. Seoul is the capital of South Korea.
2. When we went snorkeling in Waikiki, we saw a lot of fish.
3. The Lakers are my favorite basketball team.

For Numbers 4-7, write each noun in plural form.

4. manuscript _____
5. sketch _____
6. dragonfly _____
7. woman _____

For Numbers 8-10, rewrite each phrase in possessive form.

8. The pens belonging to the pigs _____
9. The howl of the wind _____
10. The curbs of the streets _____

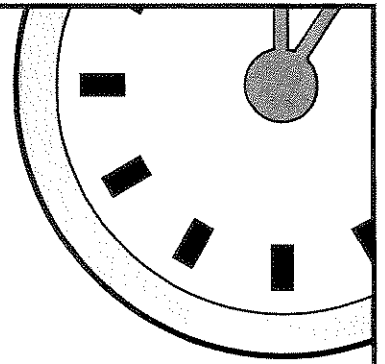
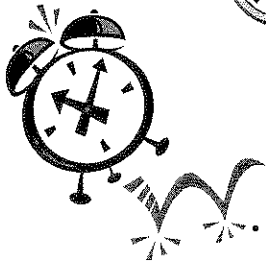

Minute 86

Name _____

For Numbers 1-2, replace the underlined word(s) with a pronoun.

1. Claude enjoys riding his bike and playing tennis. _____
2. Paula and I went fishing at the stream. _____

For Numbers 3-7, circle the correct pronoun to complete each sentence.

3. Mr. Price asked Laura and (I/me) to deliver the package.
4. The blue and red skateboards belong to (we/us).
5. Tracy brought flowers for (her/she) and me.
6. (He/Him) and (I/me) will go to school on the bus.
7. I brought a release form for (her/she) so she could attend the field trip.

For Numbers 8-10, circle the pronoun in each sentence.

8. Everyone will make a ceramic bowl.
9. Will somebody please answer the door?
10. Anyone can play on the volleyball team.

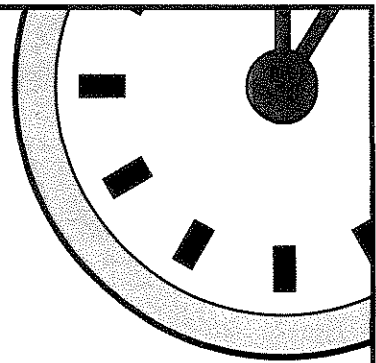
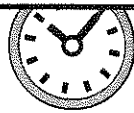

Minute 87

Name _____

For Numbers 1-5, replace the underlined word(s) with a pronoun.

1. The tabby cat cleaned the tabby cat's paw. _____
2. Jason and Brenda put on Jason and Brenda's uniforms. _____
3. We can fit two cars in my family's garage. _____
4. Lee always listens to Mr. Daley's radio program in the morning. _____
5. Dana wrote an essay and turned in Dana's paper in the morning. _____

For Numbers 6-10, circle the correct pronoun to complete each sentence.

6. "Kevin and Travis, keep your comments to _____."
yourselves yourself
7. The football fans showed their support by dressing _____ in school colors.
yourselves themselves
8. We looked at _____ in the photograph.
ourselves ourself
9. The man sat by _____ on the bench in the park.
itself himself
10. When Jenna fell on the rocks, she injured _____ badly.
herself themselves

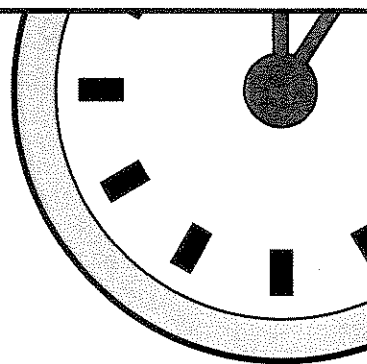

Minute 88

Name _____

For Numbers 1-2, underline the verb in each sentence.

1. Right Away grocery store sells four different types of squash.
2. The Australian swimmer is the winner.

For Numbers 3-6, write each verb in past tense form.

Present Tense	Past Tense
3. begin	_____
4. expect	_____
5. wear	_____
6. decide	_____

For Numbers 7-10, circle the correct verb to complete each sentence.

7. Please (lay/lie) your bag on the bench.
8. The village men (sit/set) outside their huts in the evenings.
9. The sun (raises/rises) in the east.
10. The date to return the library books has (passed/past).

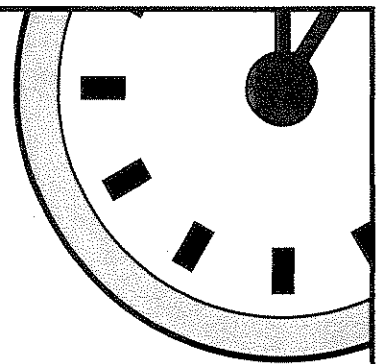

Minute 89

Name _____

For Numbers 1–5, circle the correct verb form to complete each sentence.

1. Cats _____ chasing mice and birds.
 enjoy enjoys
2. Ken and James _____ excellent writers.
 is are
3. Dad _____ into the empty parking space.
 pull pulls
4. There _____ dozens of bicycles locked in the rack.
 were was
5. Daisy _____ to finish her book report tonight.
 hope hopes

For Numbers 6–10, circle the correct pronoun to complete each sentence.

6. Girls can store P.E. clothes in (their/her) lockers.
7. Pilots must train extensively before earning (their/his) licenses.
8. Any girl who finishes early may work on (her/their) homework.
9. The doctors finished (their/his) rounds and went home.
10. We ran away fast when we saw the skunk lift
(their/its) tail.



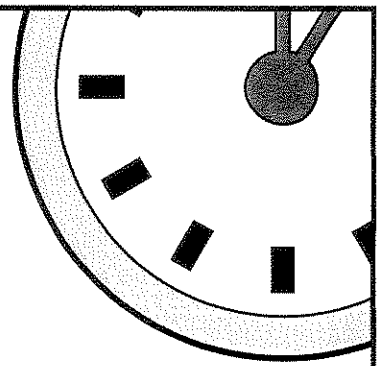
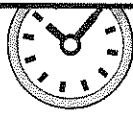

Minute 90

Name _____

Circle the correct form of the adjective to complete each sentence.

1. Chocolate ice cream is (more good/better) than vanilla.
2. The Metro Maple Leafs are the (worse/worst) team in the entire league.
3. The Bucking Bronco roller coaster is (more exciting/most exciting) than the Free Fall ride.
4. Which jar has (most/more) coffee?
5. The (most creative/more creative) designer in the contest will win a new car.
6. The overhead light is the (brighter/brightest) light in the entire room.
7. It is (more colder/colder) in Alaska than in Florida.
8. That is the (weirder/weirdest) insect I've ever seen.
9. The student with the (most clever/cleverest) idea will win the prize.
10. A gold medal is awarded to the (most good/best) contestant in the Academic Decathlon.

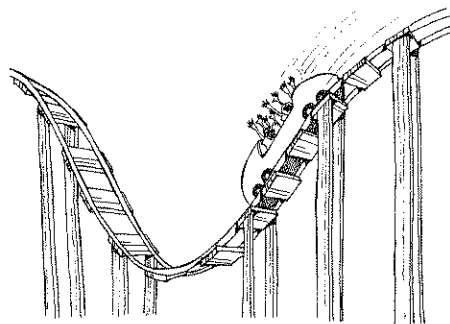

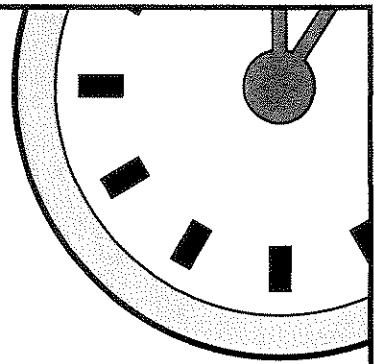
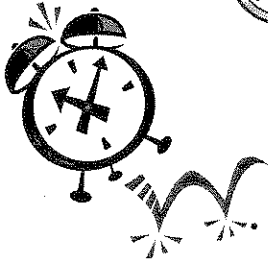

Minute 91

Name _____

For Numbers 1–5, circle the word the underlined adverb modifies.

1. Jonah waited eagerly for his appointment.
2. The boat bounced roughly on the wide blue sea.
3. The ballerina twirled daintily on her pointe shoes.
4. Bring it tomorrow.
5. Raindrops trickled slowly down the windowpane.

For Numbers 6–10, write what question the underlined adverb answers: *how, when, where, how often or to what degree.*

6. Monica exercises regularly. _____
7. Mrs. Petersen said to put the boxes here. _____
8. Dogs barked noisily as we rode past. _____
9. Charge the battery fully before using. _____
10. The wind blew the snow sideways. _____

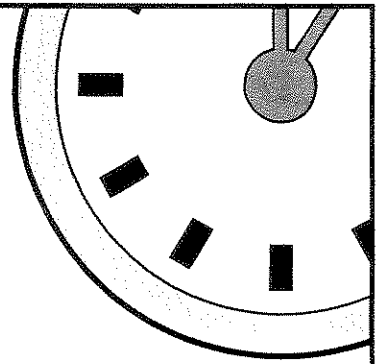

Minute 92

Name _____

For Numbers 1–3, write either *between* or *among* to correctly complete each sentence.

1. The race will be _____ Jerome and Taylor.
2. It is difficult to choose _____ the many flavors.
3. Cross the street _____ the yellow lines at the crosswalk.

For Numbers 4–10, circle the preposition(s) in each sentence.

4. The television in the living room is still not working.
5. The table under the window provides the best light for reading.
6. Gravel crunched under our feet as we walked up the driveway.
7. Maria poured juice into a tall glass.
8. Bart will play the lead role, Julius Caesar, in the school play.
9. Darlene waited all day for the dough to rise.
10. Walk around the lake and stop at the path's end.

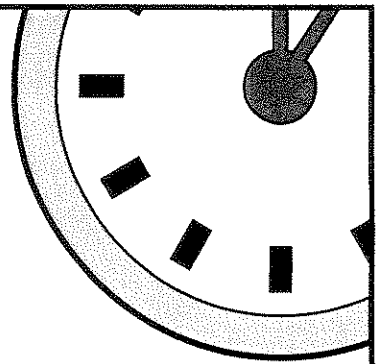

Minute 93

Name _____

For Numbers 1-3, underline the appositive in each sentence. Circle the noun phrase or pronoun it describes.

1. Wendy, my older sister, attends Willowbrook High School.
2. The prime minister, a well-respected man, made the decision to raise taxes.
3. The first woman to scale Mt. Everest, Junko Tabei of Japan, accomplished a remarkable achievement.

For Numbers 4-7, write *D* if the underlined clause is a dependent clause or *I* if the clause is an independent clause

4. The red roses in Mrs. Rueben's yard are so beautiful in the summer. _____
5. Our team won the basketball game, and we felt proud of our success. _____
6. Maddy makes jewelry, and she often gives it to her friends. _____
7. Mom hung blue curtains in my bedroom to block the morning light. _____

For Numbers 8-10, write a dependent clause to make each sentence a complex sentence.

8. The temperature outside is very cold _____.
9. Wash thoroughly with soap _____.
10. The newspaper reported a robbery _____.

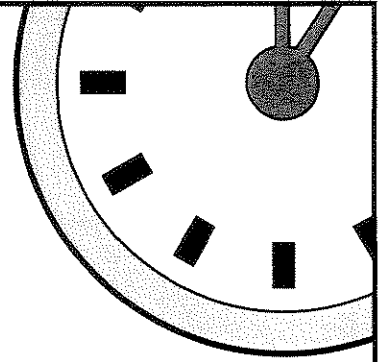

Minute 94

Name _____

Write *Yes* if the sentence is written correctly. Write *No* if it is not.

1. We don't got any money to buy a movie ticket. _____
2. It's so foggy I can't barely see anything. _____
3. We could not go to the park because it was raining. _____
4. Lisa and Benjamin don't never miss hockey practice. _____
5. Atlantic Avenue is nowhere around here. _____
6. Our mother just told us that we did not have to clean the living room. _____
7. She don't have no pen I can borrow. _____
8. Do not forget to close the door behind you. _____
9. I was not going to not do my homework. _____
10. I have not seen Sherry anywhere. _____

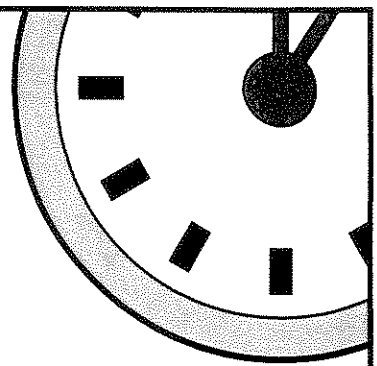

Minute 95

Name _____

Write a synonym and an antonym for each word.

Word	Synonym	Antonym
1. precious	_____	_____
2. messy	_____	_____
3. alike	_____	_____
4. many	_____	_____
5. sharp	_____	_____
6. active	_____	_____
7. dangerous	_____	_____
8. quiet	_____	_____
9. wide	_____	_____
10. brave	_____	_____

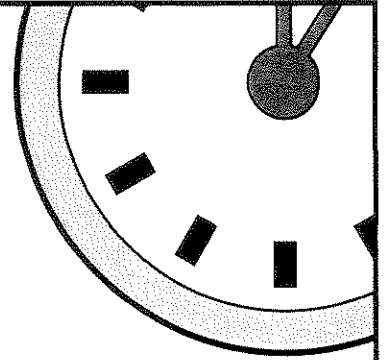
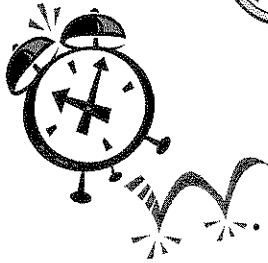

Minute 96

Name _____

For Numbers 1–5, complete each sentence with the correct homophone from the box.

reign/rein/rain
ceiling/sealing

pear/pair
guest/guessed

plain/plane

1. When the _____ began, Lindsey opened her umbrella.
2. The _____ was painted a bright blue.
3. Alex sliced the _____ and brought it to the table.
4. The students _____ how many buttons were in the jar.
5. The animals roamed the African _____.

For Numbers 6–10, write the homograph to complete each sentence.
(Hint: The word is used in the sentence.)

6. I object to having that _____ in my backpack.
7. Can you please place your _____ in the recycling bin?
8. The spring rains have made the _____ water plentiful.
9. What can you produce from the items in the _____ section of the grocery store?
10. Who will conduct the orchestra if her _____ is unacceptable?

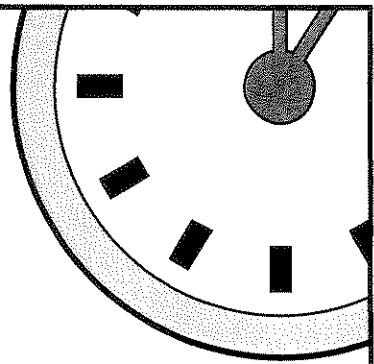
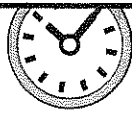

Minute 97

Name _____

For Numbers 1–5, add a suffix to change the meaning of each word. Use each suffix in the box only once.

-ness -ible -ish -ly -en

1. sincere _____

4. self _____

2. bright _____

5. flex _____

3. quick _____

For Numbers 6–10, add a prefix to each word and write its definition. Use each prefix in the box only once.

pre- un- in- im- dis-

Word with Prefix

Definition

6. _____ similar

7. _____ comfortable

8. _____ fix

9. _____ visible

10. _____ possible

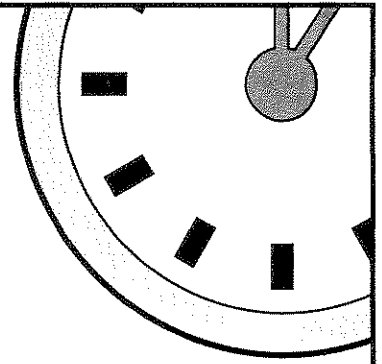
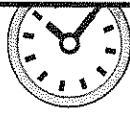
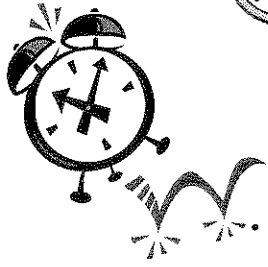

Minute 98

Name _____

For Numbers 1-4, draw a line from the Latin or Greek root to its meaning. Draw another line from the meaning to the sample word.

Root	Definition	New Word
1. ology •	• study of •	• biography
2. port •	• water •	• geology
3. aqua •	• writing •	• portable
4. graph •	• to carry •	• aquarium

For Numbers 5-7, add a prefix to change the meaning of each word. Use the prefixes in the box.

5. _____ port

6. _____ word

7. _____ wind

re-	fore-	trans-
-----	-------	--------

For Numbers 8-10, add a suffix to change the meaning of each word. Use the suffixes in the box.

8. graph _____

9. flavor _____

10. profess _____

-ful	-or	-ic
------	-----	-----

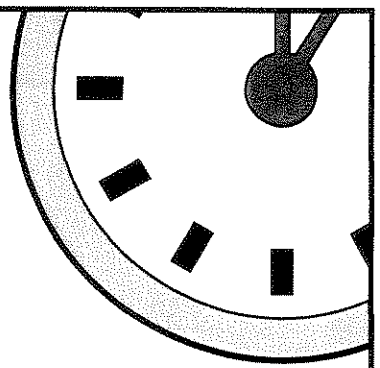
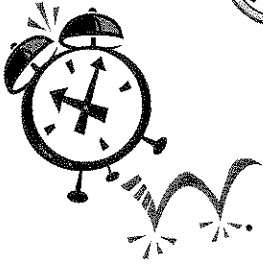

Minute 99

Name _____

Circle all the words that need to be capitalized in each sentence.

1. Wall Street is a street located near South street Seaport in New York city.
2. Before it became the financial center of the united states, Wall Street was the center of government.
3. New York was the capital of early america, and all the government offices were located on Wall Street.
4. george washington was inaugurated in the city of New York.
5. Many impressive buildings make up the Wall street neighborhood.
6. Federal hall and the trump towers are landmark buildings on Wall Street.
7. The New York stock exchange is one of the most important buildings in the city.
8. The site where the World Trade Center stood prior to september 11, 2001, is slated to become the Freedom tower.
9. If you ever have the chance to visit our nation's former capital, take the opportunity. Then compare the city life between washington, d.c., and New York.
10. Many people mistakenly believe that New York City is the capital of new york state, but the capital is actually albany. This mistake just shows how important New York City is!

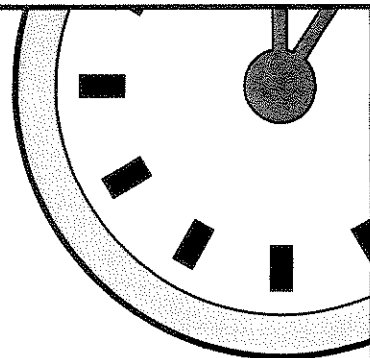
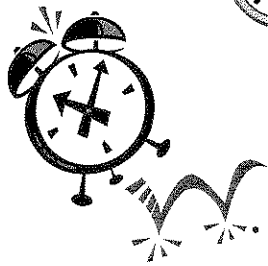

Minute 100

Name _____

Insert commas and end punctuation in the correct places in each sentence.

1. The tropical rain forests of South America Africa and Southeast Asia are always warm and wet
2. Animals such as birds and bats live in the rain forests
3. Did you know many animals in the tropical rain forest live in trees
4. Mom said "Pack up kids we're going to Water World"
5. An hour later there were eight of us in the van
6. The trip to Water World takes over an hour so we sang songs on the way
7. We went on the junior slides the taller slides and the slippery slope but no one dared go on the Wild Riot
8. "That was the most fun I ever had" exclaimed Robert
9. "Can we go again" asked Vanessa
10. Later after all of us were in bed we talked about all of the fun we had

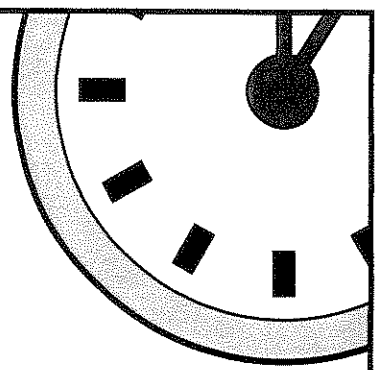

Minute Answer Key

Minute 1

- | | |
|------|-------|
| 1. C | 6. C |
| 2. I | 7. I |
| 3. I | 8. C |
| 4. C | 9. C |
| 5. I | 10. I |

Minute 2

- Ella
- squid
- stars
- Petronas Towers
- phones
- painted
- is
- sway
- is awarded
- came

Minute 3

- My sister Lindsey
- The brand-new building
- Alex's sister
- The elementary school students
- The eager group of tourists
- put his books in my backpack
- is a fun winter sport
- helped the flowers bloom
- politely handed me my receipt
- will take her place

Minute 4

- Gretchen and Thelma
- roses and daisies
- Sweaters, coats, and rugs
- The guard and the center
- The United States, Canada, and Mexico

For Numbers 6-10, answers will vary. Sample answers include:

- wiped
- splashed
- downloaded
- washes
- pack

Minute 5

- circle: Look at that!
underline: Isn't that a gorgeous sunset?
- circle: I can't believe I missed the bus!
underline: What will I do now?

- circle: It's unbelievable!
underline: Was that your fastest swim record?

- circle: I can't believe it's broken!
underline: How long will it be before we can get it repaired?

- !, ., ?
- !, ?
- ?, !, . or !

For Numbers 8-10, answers will vary.

Sample answers include:

- I'm so hungry!
- Please lower your voices!
- You really have to try this!

Minute 6

- | | |
|------|-------|
| 1. I | 6. I |
| 2. D | 7. D |
| 3. I | 8. I |
| 4. I | 9. I |
| 5. D | 10. D |

Minute 7

- | | |
|------|-------|
| 1. . | 6. . |
| 2. ? | 7. I |
| 3. . | 8. . |
| 4. ! | 9. . |
| 5. ? | 10. ? |

Minute 8

- | | |
|------|-------|
| 1. . | 6. I |
| 2. . | 7. I |
| 3. . | 8. . |
| 4. I | 9. I |
| 5. . | 10. I |

Minute 9

- | | |
|------|-------|
| 1. S | 6. S |
| 2. P | 7. S |
| 3. P | 8. P |
| 4. P | 9. S |
| 5. P | 10. P |

Minute 10

- circle: virus
underline: A virus
- circle: Great Egyptian Pyramids
underline: The Great Egyptian Pyramids
- circle: Heather and Tony
underline: My good friends Heather and Tony
- circle: robin
underline: The bright red robin
- circle: hot chocolate
underline: The steaming hot chocolate

For Numbers 6-10, answers will vary.

Sample answers include:

- Martin walked to school and pulled open the school doors.
- All plants use oxygen and take in water.
- My mother washed and curled her hair.
- Many Brazilians love to watch and play soccer.
- Rachel strolled along the boardwalk and looked at the view.

Minute 11

- | | |
|-----------|-----------|
| 1. ., D | 6. ., IMP |
| 2. ?, I | 7. ., D |
| 3. !, E | 8. ?, I |
| 4. ., IMP | 9. !, E |
| 5. ?, I | 10. ., D |

Minute 12

Order of answers within each category may vary.

Person

- explorer
- veterinarian
- woman

Place

- city
- park
- post office

Thing or idea

- bread
- liberty
- bucket
- friendship

Minute 13

- underline: friends
circle: Jeff, Onondaga Camp
- underline: glove
circle: Javier
- underline: game
circle: Central Park
- underline: students, causes
circle: Revolutionary War
- underline: ingredients
circle: Steven
- underline: house
circle: Nick's
- underline: teacher
circle: Hyde's Planetarium
- underline: day
circle: Byron Elementary School
- underline: president
circle: United States, White House
- underline: pictures

circle: Venus

Minute 14

- Brazil
- Budapest
- Chinese
- Diwali
- Eiffel Tower
- Torah
- Muslims
- Vatican City
- Juanita
- Walt Disney Concert Hall

Minute 15

- shoes
- heroes
- boxes
- skates
- monkeys
- companies
- princesses
- cherries
- witches
- chimneys

Minute 16

- children, places
- photos, deer
- dishes, potatoes
- families, blessings
- sheep, hills
- pens, shelves
- leaves, piles
- friends, quizzes
- doors, elves
- movies, biographies

Minute 17

- The spider's web
- Teresa's cookie
- Kenneth's flute
- The student's lunch
- The doctor's stethoscope
- The child's father
- Ann's shoes
- The map's legend
- The team's mascot
- The writer's biography

Minute 18

- The boys' team
- The teachers' lounge
- The ships' captains
- The stores' computers
- The children's classroom
- The women's dresses
- The partners' projects
- The leaves' colors
- The oxen's harnesses
- The deer's hooves

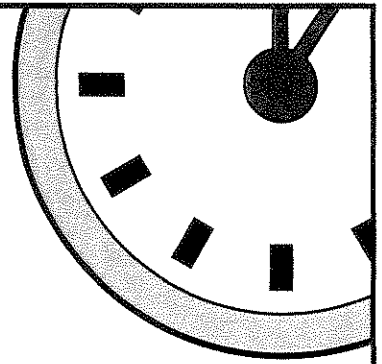
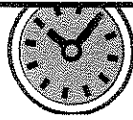

Minute Answer Key

Minute 19

- | | |
|---------|-------------|
| 1. He | 6. us |
| 2. They | 7. her, me |
| 3. She | 8. us |
| 4. He | 9. her, me |
| 5. They | 10. him, me |

Minute 20

- | | |
|---------------|------------|
| 1. myself | 6. her |
| 2. himself | 7. my, his |
| 3. yourselves | 8. Whose |
| 4. itself | 9. mine |
| 5. ourselves | 10. Your |

Minute 21

- | | |
|---------|-------------|
| 1. who | 6. Anyone |
| 2. that | 7. anything |
| 3. who | 8. somebody |
| 4. that | 9. everyone |
| 5. who | 10. Each |

Minute 22

- | | |
|-------------|-------------|
| 1. they are | 6. its |
| 2. their | 7. their |
| 3. her | 8. her |
| 4. his | 9. they are |
| 5. their | 10. they |

Minute 23

- underline: sandwich
circle: Charlene
- underline: guitar
circle: Melody Music Shop
- underline: birthday
circle: Parker's, January
- underline: race
circle: Tour de France, France
- underline: theater
circle: Monday
- underline: squirrel, trees
circle: Highland Park
- underline: apartment, floor
circle: None
- underline: banker, loan
circle: Louise
- underline: None
circle: Statue of Liberty, New York City
- underline: garbage
circle: None

Minute 24

For Numbers 1-5, order of answers may vary.

- | | |
|-------------|------------|
| 1. climbers | 6. beetles |
| 2. knives | 7. hobbies |
| 3. utensils | 8. mice |
| 4. months | 9. halves |
| 5. people | 10. echoes |

Minute 25

- men's department
- Cindy's bookshelf
- galleries' windows
- kindergartner's crayons
- runners' water bottles
- underline: Melissa's motorcycle
circle: friends' motorcycles
- underline: Dad's day
circle: Dolphins' victory
- underline: Jessica's allergies
circle: flowers' pollen
- underline: Daria's Grocery Store
circle: dogs' loud barking
- underline: Lisa's pet hamster
circle: sofas' slippery cushions

Minute 26

- | | |
|-------------|---------|
| 1. me | 6. He |
| 2. her | 7. It |
| 3. them | 8. It |
| 4. her, him | 9. They |
| 5. him, me | 10. We |

Minute 27

- | | |
|------------------------|---------------|
| 1. his | 5. our |
| 2. Their or His or Our | 6. himself |
| 3. their | 7. herself |
| 4. her | 8. themselves |
| | 9. yourself |
| | 10. itself |

Minute 28

- | | |
|---------|---------|
| 1. who | 6. No |
| 2. that | 7. Yes |
| 3. that | 8. No |
| 4. that | 9. No |
| 5. who | 10. Yes |

Minute 29

Answers for second verb will vary.

- soars, flies
- drives, travels
- sparkle, twinkle
- leaps, bounds
- skate, blade
- cuts, gathers
- lost, misplaced
- sails, floats
- swims, explores
- hit, batted

Minute 30

- | | |
|---------|-------|
| 1. is | 6. a |
| 2. am | 7. b |
| 3. are | 8. b |
| 4. are | 9. b |
| 5. were | 10. a |

Minute 31

- | | |
|-------------|-----------|
| 1. sailed | 6. acted |
| 2. screamed | 7. wore |
| 3. flew | 8. wrote |
| 4. answered | 9. boiled |
| 5. grew | 10. broke |

Minute 32

- | | |
|--------------|--------------|
| 1. invented | 6. offering |
| 2. hunted | 7. ruled |
| 3. joking | 8. planning |
| 4. mentioned | 9. unloading |
| 5. moving | 10. visiting |

Minute 33

- | | |
|---------|-----------|
| 1. lay | 6. raised |
| 2. lies | 7. lay |
| 3. set | 8. passed |
| 4. sit | 9. sat |
| 5. rise | 10. lay |

Minute 34

- I laugh, You laugh, She laughs, They laugh
- I ask, You ask, He asks, They ask
- I start, You start, It starts, They start
- I paint, You paint, He paints, They paint
- I dance, You dance, She dances, They dance
- mop
- plants
- stings
- turns
- ignores

Minute 35

- | | |
|----------|-----------|
| 1. is | 6. are |
| 2. earns | 7. are |
| 3. is | 8. drives |
| 4. are | 9. wear |
| 5. are | 10. are |

Minute 36

- circle: raced
 - circle: melts
 - underline: was
 - circle: built
 - underline: is
- For Numbers 6-10, answers will vary. Sample answers include:
- The snow fell from the dark sky.
 - The sun is shining down on the buildings.
 - My friend and I laughed and danced at the concert.
 - Lisa yawned and stretched.
 - My stomach grumbled loudly.

Minute 37

- | | |
|------|-------|
| 1. H | 6. H |
| 2. L | 7. L |
| 3. L | 8. H |
| 4. H | 9. L |
| 5. H | 10. L |

Minute 38

- ran
- dove
- froze
- walked
- thought
- sweeping
- dried
- marching
- stretched
- exploded

Minute 39

- | | |
|-----------|--------|
| 1. lay | 6. Yes |
| 2. lie | 7. No |
| 3. set | 8. No |
| 4. passed | 9. Yes |
| 5. raise | 10. No |

Minute 40

- | | |
|------------|-----------|
| 1. expects | 6. is |
| 2. flops | 7. wishes |
| 3. were | 8. eats |
| 4. are | 9. are |
| 5. plans | 10. uses |

Minute 41

- awkward
- magic
- delicious
- tiny, black, white
- dirty, smelly
- unpredictable
- beautiful
- demanding
- little, green
- mashed

Minute 42

- helpful or kind
- dangerous
- exquisite
- speedy
- plump or immense
- contented
- level
- helpful or kind
- immense
- playful

Minute 43

- smoother
- fresher
- more general
- more difficult
- more jealous
- kinder

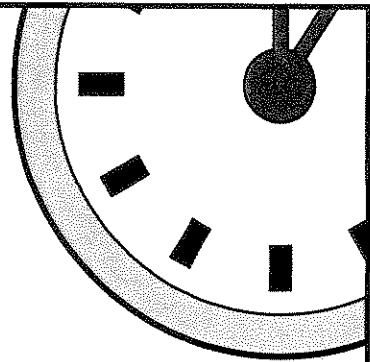
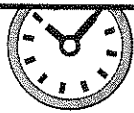
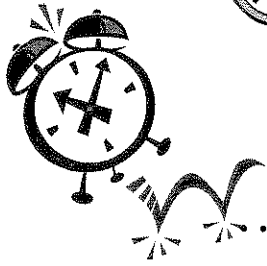

Minute Answer Key

Minute 84

- underline: Babies
circle: cry
- underline: The swimmers
circle: raced to the finish line
- underline: The city of Los Angeles
circle: hosted the 1984 Olympic Games
- underline: A rusty old car
circle: sat abandoned on the side of the road
- No
- Yes
- No
- ?, interrogative
- !, exclamatory
- ., declarative

Minute 85

- underline: capital
circle: Seoul, South Korea
- underline: snorkeling, fish
circle: Waikiki
- underline: team
circle: Lakers
- manuscripts
- sketches
- dragonflies
- women
- pigs' pens
- wind's howl
- streets' curbs

Minute 86

- He
- We
- me
- us
- her
- He, I
- her
- Everyone
- somebody
- Anyone

Minute 87

- its
- their
- our
- his
- her
- yourselves
- themselves
- ourselves
- himself
- herself

Minute 88

- | | |
|-------------|------------|
| 1. sells | 6. decided |
| 2. is | 7. lay |
| 3. began | 8. sit |
| 4. expected | 9. rises |
| 5. wore | 10. passed |

Minute 89

- | | |
|----------|----------|
| 1. enjoy | 6. their |
| 2. are | 7. their |
| 3. pulls | 8. her |
| 4. were | 9. their |
| 5. hopes | 10. its |

Minute 90

- better
- worst
- more exciting
- more
- most creative
- brightest
- colder
- weirdest
- cleverest
- best

Minute 91

- waited
- bounced
- twirled
- Bring
- trickled
- how often
- where
- how
- to what degree
- how

Minute 92

- between
- among
- between
- in
- under, for
- under, up
- into
- in
- for
- around, at

Minute 93

- underline: my older sister
circle: Wendy
- underline: a well-respected man
circle: The prime minister
- underline: Junko Tabei of Japan
circle: The first woman to scale Mt. Everest
- D
- I

- I
- D

For Numbers 8-10, answers will vary.
Sample answers include:

- The temperature outside is very cold when it's winter.
- Wash thoroughly with soap before handling food.
- The newspaper reported a robbery in the west part of town.

Minute 94

- | | |
|--------|---------|
| 1. No | 6. Yes |
| 2. No | 7. No |
| 3. Yes | 8. Yes |
| 4. No | 9. No |
| 5. Yes | 10. Yes |

Minute 95

Answers will vary. Sample answers include:

- synonym: prized
antonym: worthless
- synonym: cluttered
antonym: neat
- synonym: same
antonym: dissimilar
- synonym: numerous
antonym: few
- synonym: spiky
antonym: blunt
- synonym: energetic
antonym: idle
- synonym: hazardous
antonym: safe
- synonym: silent
antonym: loud
- synonym: broad
antonym: narrow
- synonym: heroic
antonym: spineless

Minute 96

- | | |
|------------|-------------|
| 1. rain | 6. object |
| 2. ceiling | 7. can |
| 3. pear | 8. spring |
| 4. guessed | 9. produce |
| 5. plain | 10. conduct |

Minute 97

- sincerely or sincereness
 - brighten, brightness, or brightly
 - quickness, quicken, or quickly
 - selfish or selfness
 - flexible
- For Numbers 6-10, answers will vary.
Sample answers include:
- dissimilar, not the same
 - uncomfortable, not at ease
 - prefix, something set before

- invisible, not able to be seen
- impossible, not able to do

Minute 98

- study of, geology
- to carry, portable
- water, aquarium
- writing, biography
- transport
- foreword
- rewind
- graphic
- flavorful
- professor

Minute 99

- Street, City
- United States
- America
- George Washington
- Street
- Hall, Trump Towers
- Stock Exchange
- September, Tower
- Washington, D.C.
- New York State, Albany

Minute 100

- The tropical rain forests of South America, Africa, and Southeast Asia are always warm and wet.
- Animals such as birds and bats live in the rain forests.
- Did you know many animals in the tropical rain forest live in trees?
- Mom said, "Pack up, kids. We're going to Water World!"
- An hour later, there were eight of us in the van.
- The trip to Water World takes over an hour, so we sang songs on the way.
- We went on the junior slides, the taller slides, and the slippery slope, but no one dared go on the Wild Riot.
- "That was the most fun I ever had!" exclaimed Robert.
- "Can we go again?" asked Vanessa.
- Later, after all of us were in bed, we talked about all of the fun we had.